



Draft – Work in Progress. Subject to Revision

Washington Briefing
Deepwater Horizon Interim Incident Investigation

24th May 2010



Content

Draft – Work in Progress. Subject to Revision

24 May, 2010

- Investigation Overview
- Macondo Well Key Components & Critical Factors
- Critical Factors & Ongoing Work



Investigation Overview

Draft – Work in Progress. Subject to Revision

24 May, 2010

- The Terms of Reference is focused on determining facts and causation
- Investigation team comprises ~ 70 internal and external personnel (inclusive of technical staff supported by legal, documentation and other support disciplines)
- Investigation based on:
 - Reports
 - Engineering drawings
 - Real-time data transmitted from the rig
 - Witness accounts (personnel both on the rig and others involved in operations and planning of Macondo Well)
 - Modeling & analysis
 - Aim to test equipment (cement sample, float collar, BOP)
- Investigation & analysis has access to limited physical evidence only
- Some key third party interviews and data have not yet been available

Macondo Well Diagram – Key Components & Critical Factors

Draft – Work in Progress. Subject to Revision



24 May, 2010

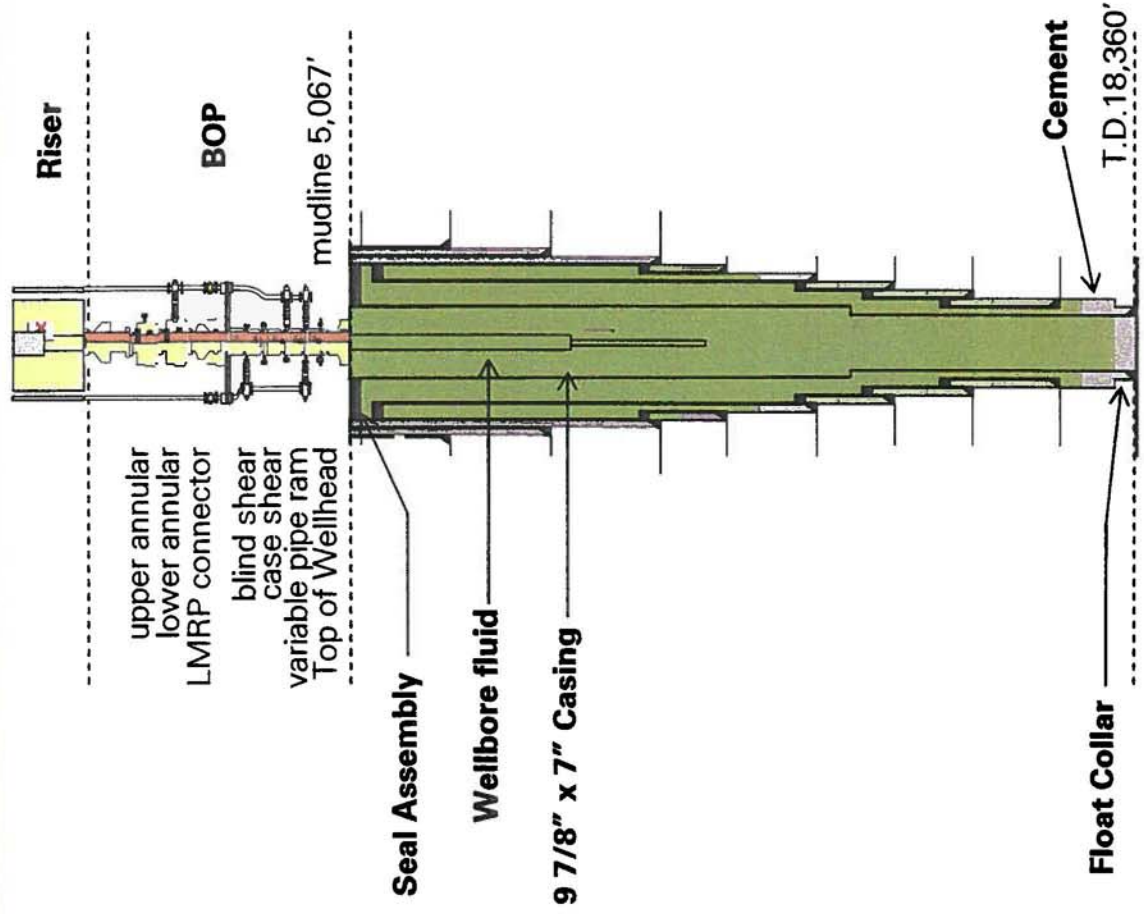

Critical Factors

1. Loss of Integrity of the 9 7/8" x 7" casing created a path for hydrocarbon (HC) influx
2. Unrecognized well conditions
 - Influx unrecognized - Integrity test failed to identify communication with the reservoir
 - Operations allowed HC influx to enter and move up the well bore – well became capable of flowing
 - Response failed to control the well
3. BOP & Emergency Systems failed to isolate the HC source
4. Gas plume ignited

Not All Information has been verified / corroborated. Subject to review in light of additional information or analysis



Critical Factor 1 – Loss of Integrity of Casing

Draft – Work in Progress. Subject to Revision

24 May, 2010

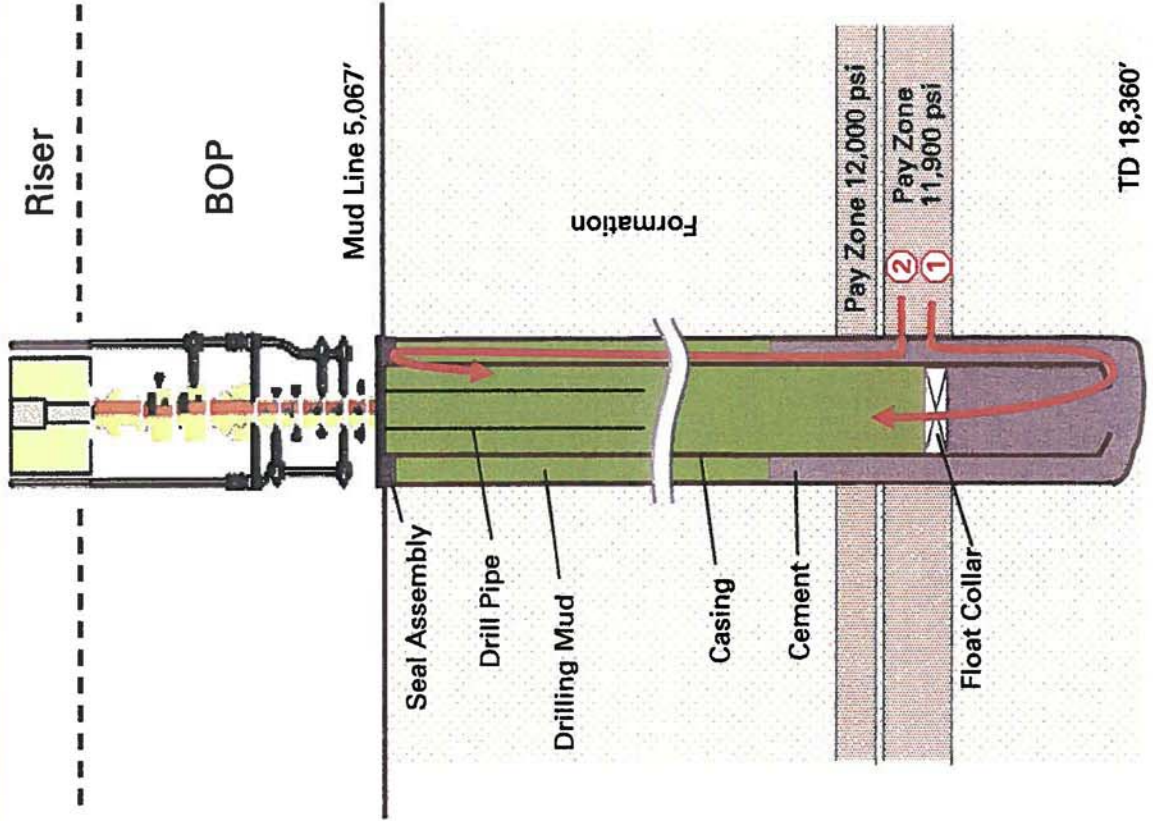

Loss of Integrity of 9-7/8" x 7" Casing

- Cement failed to isolate the reservoir
- The float collar (1) or the seal assembly (2) leaked

On-going work & forward plans

- Review design and execution of the cement job
- Review design and installation of casing shoe track and seal assembly
- Laboratory testing of float collar
- Detailed well dynamic modeling to assess likely influx point

Not All Information has been verified / corroborated. Subject to review in light of additional information or analysis



Critical Factor 2 – Unrecognized Well Conditions

Draft – Work in Progress. Subject to Revision

24 May, 2010

Unrecognized Well Conditions

- Integrity test failed to identify communication with the reservoir
- Operations allowed HC influx to enter and move up the well bore – **well became capable of flowing**
- Rig crew response to well flow failed to control the well

Ongoing work & forward plans

- Reconstruct timeline from available data and interviews to estimate when influx occurred and when it should have been recognized
- Try to ascertain why well flow conditions were not detected earlier
- Try to ascertain rig crew response to well flow conditions
- Review integrity testing procedure
- Transocean interviews when possible

Not All Information has been verified / corroborated.
Subject to review in light of additional information or analysis



Critical Factor 3 – BOP Failed to Isolate Source

Draft – Work in Progress. Subject to Revision

24 May, 2010

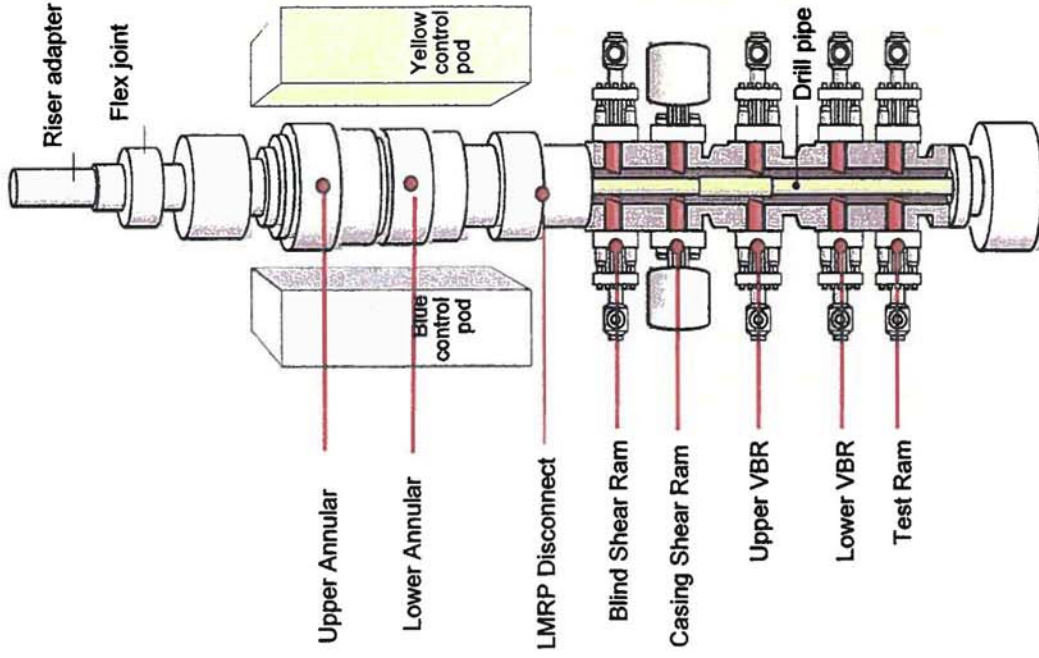

BOP Failed to Isolate Source

- Action to activate the BOP once well condition was recognized failed to isolate the source
- EDS failed to secure the well (when activated from bridge after explosion)
- AMF/Dead-man failed to secure well
- Subsequent ROV interventions failed to secure the well

Ongoing work & forward plans

- Understand BOP testing history and performance of emergency systems, EDS, Auto shear, AMF (Deadman), ROV hot stab
- Understanding of BOP modifications – could they have affected its functionality?
- Assess leaks identified during ROV intervention and determine significance – could they have affected its functionality?
- Evaluation of BOP maintenance history regards system completeness, OEM parts and 3rd party services
- Inspect & test BOP once retrieved from sea floor

Not All Information has been verified / corroborated. Subject to review in light of additional information or analysis



Critical Factor 4 – Ignition of Hydrocarbons

Draft – Work in Progress. Subject to Revision

24 May, 2010

Hazardous Area Classification - Main Deck

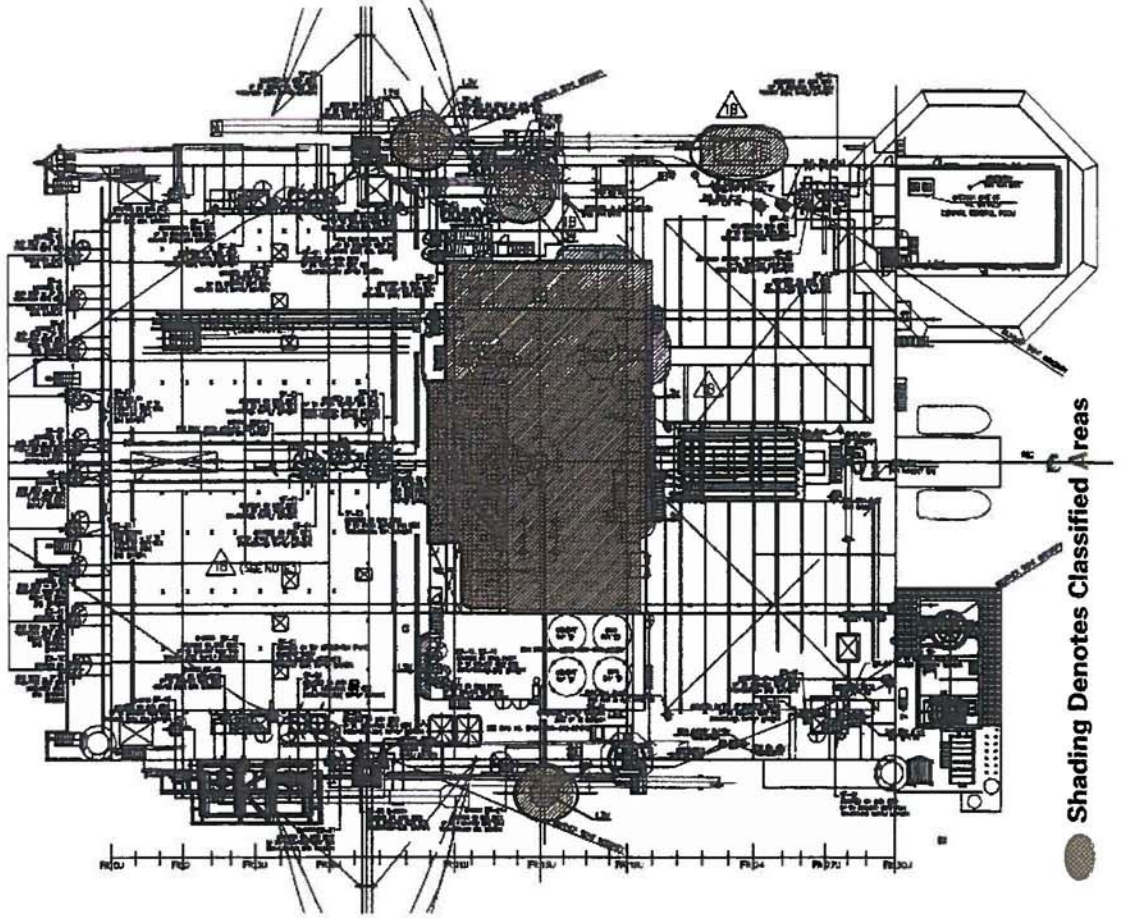

Ignition of Released Hydrocarbons

- Hydrocarbon gas detected by several gas detectors prior to explosion (two witness statements from bridge).
- Several potential scenarios of hydrocarbon release to atmosphere have been identified.
- Dynamic modeling estimates suggests that flammable gas mixtures could have reached non-electrically classified areas.

Ongoing work

- Fluid dynamic modeling being further developed in-line with most probable release scenarios.
 - Access to pit room / mud pumps
 - Access to derrick via degasser
 - Access to engine room
- Review of electrical area classification, fire and gas design and ventilation system design.

Not All Information has been verified / corroborated. Subject to review in light of additional information or analysis

● Shading Denotes Classified Areas



Draft – Work in Progress. Subject to Revision

Deepwater Horizon Incident Timeline and Animation of Events

Presented May 24, 2010 in Washington D.C.



Finish Drilling and Complete Logging

Draft – Work in Progress. Subject to Revision

4/9/10 - 4/15/10

Last BOP pressure test: 4/10/2010
All tests passed

Data
<ul style="list-style-type: none"> Finish drilling <ul style="list-style-type: none"> 9-7/8" x 8-1/2" open hole 14.0 ppg mud inside and out Trip out with drilling assembly Wireline log for 4 days

Interpretation
<ul style="list-style-type: none"> Hole stable

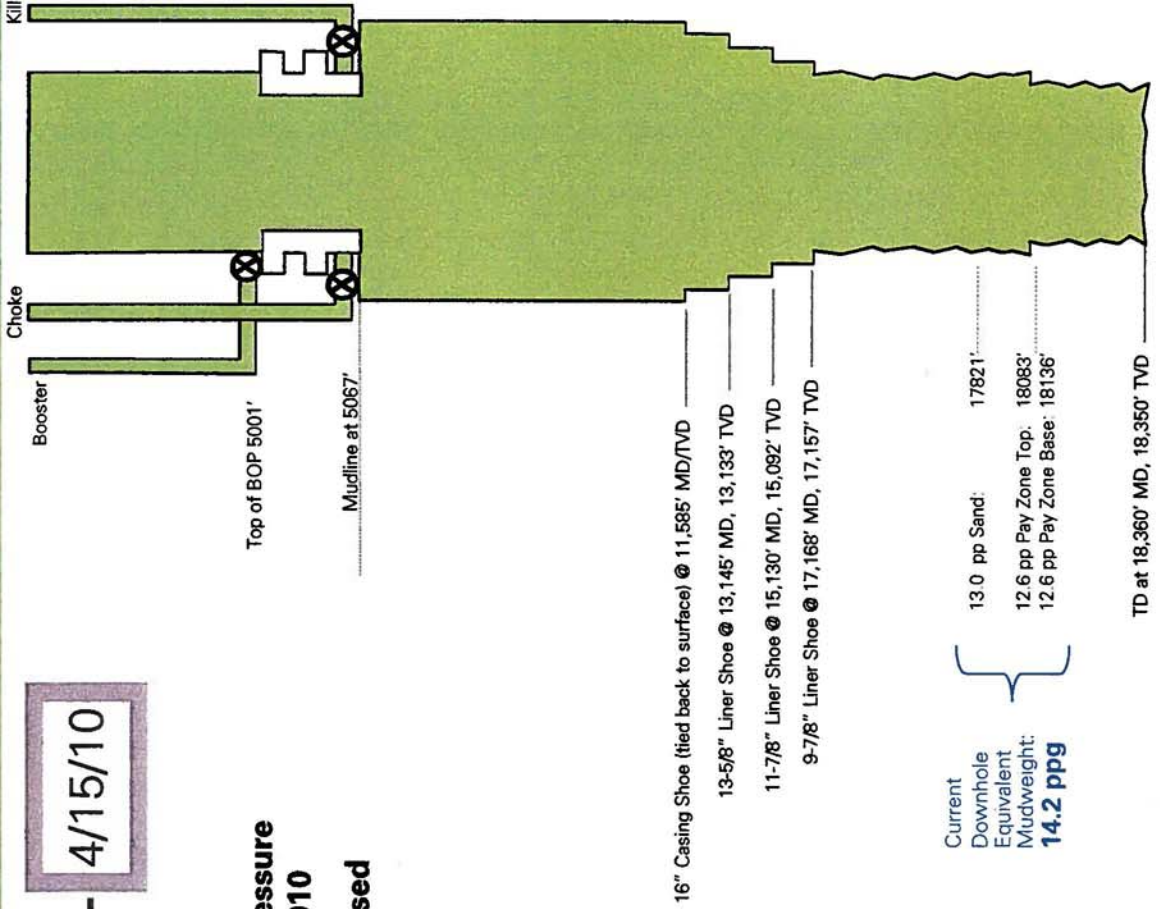



Wiper Trip

Draft – Work in Progress. Subject to Revision

14:00 - 12:00
4/16/10 - 4/17/10

Function test BOP:
4/17/10 at 01:00
Function test diverter:
4/17/10 at 01:30

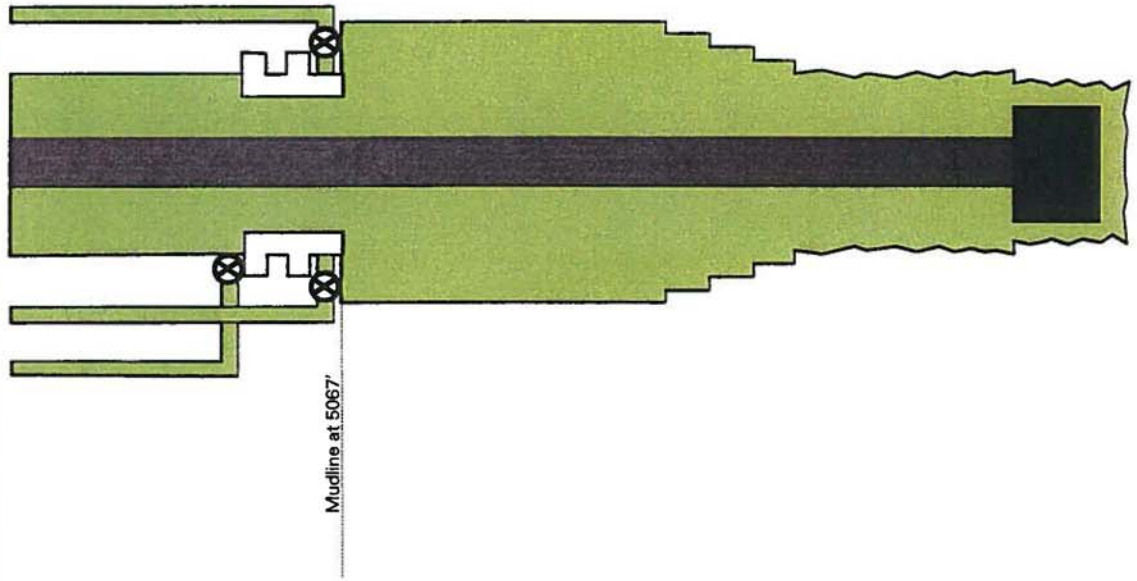

<u>Data</u>
<ul style="list-style-type: none"> • Run in hole for wiper trip <ul style="list-style-type: none"> – Circulate bottoms up at TD – Pump high vis sweep – Monitor for gains or losses – none – 14.0 ppg clean mud throughout before trip out • Pump out from 18360' – 14759' <ul style="list-style-type: none"> – 4 flow checks during trip out – no flow

<u>Interpretation</u>



Retrieve Wear Sleeve

Draft – Work in Progress. Subject to Revision

12:00 - 00:30

4/17/10 - 4/18/10

Function test BSR
4/17/10 23:00

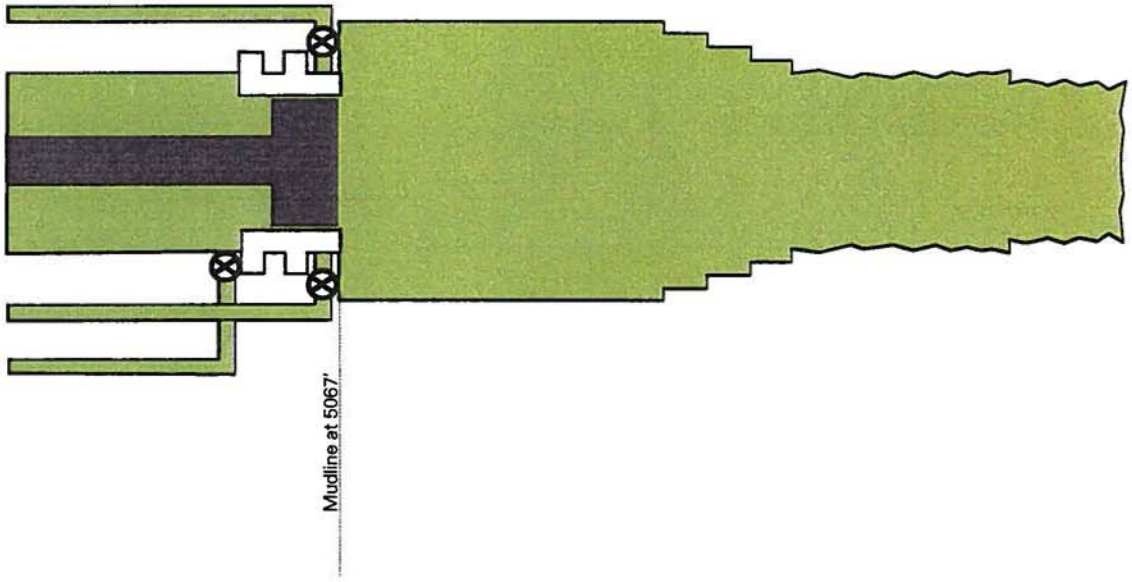

<u>Data</u>
<ul style="list-style-type: none">• Make trip to retrieve wear sleeve– Retrieval successful

<u>Interpretation</u>



Run Casing – Convert Float Equipment

Draft – Work in Progress. Subject to Revision

00:30 - 17:30
4/18/10 - 4/19/10

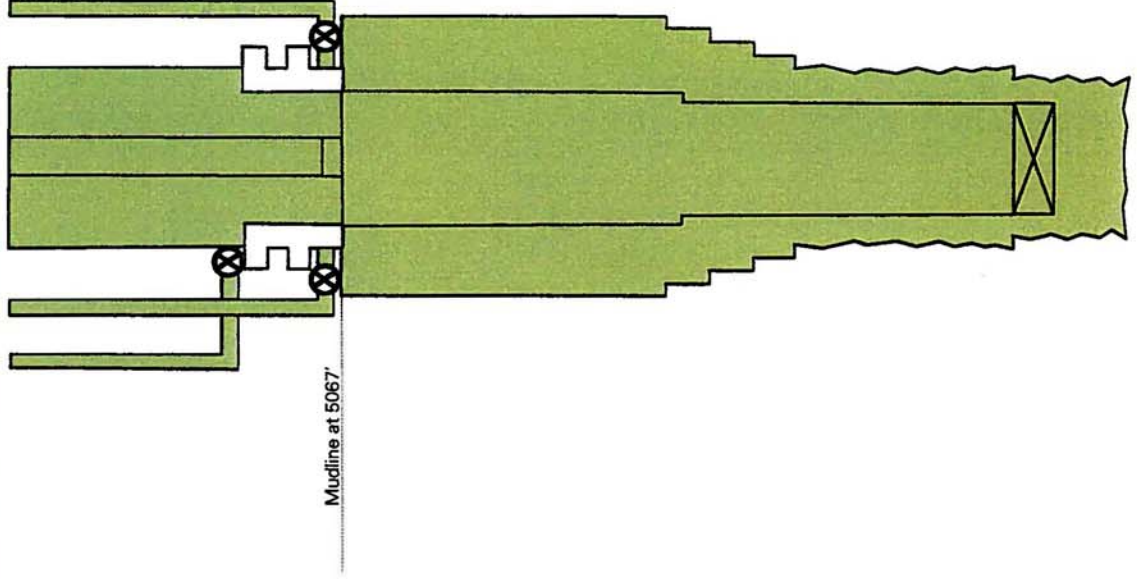

Data

- Run 7" x 9-7/8' production casing
 - Crossover at 12487'
 - Float Collar at 18114'
 - Shoe at 18304'
 - 56' of rat hole
- Laid out three joints of 7" due to damaged threads
- Saw 10k weight bobble at 18218 (only time string took weight during run)
- 9 attempts to convert float equipment
 - Sheared at 3142 psi vs 500-700 psi design

Interpretation

- Circulating pressure below normal after shearing float collar



Cement Job

Draft – Work in Progress. Subject to Revision

17:30 - 00:30
4/19/10 - 4/20/10

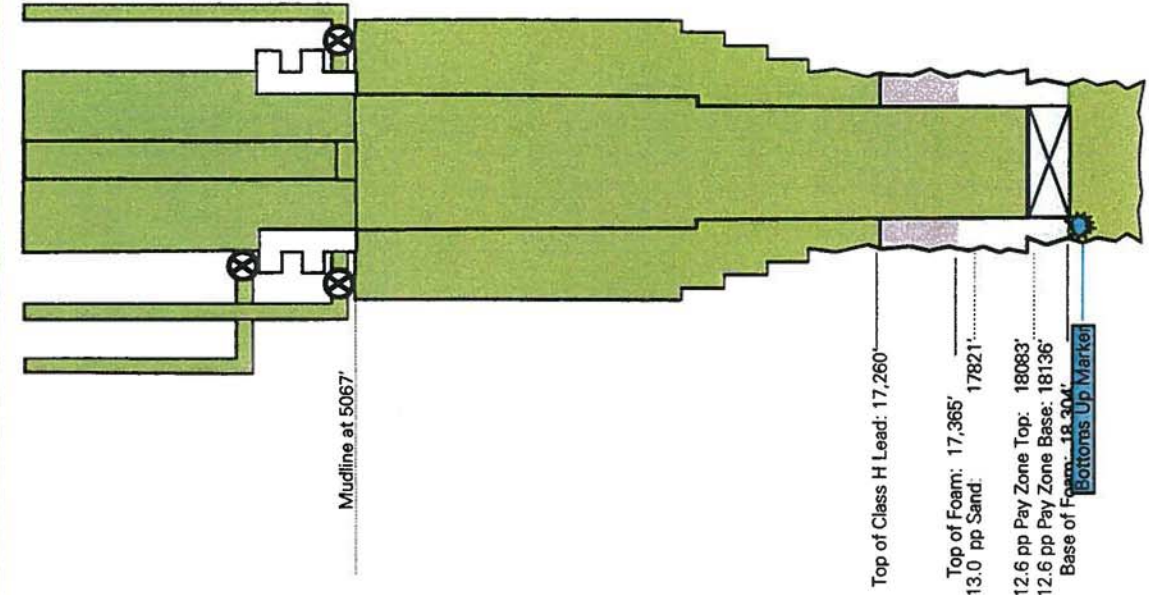
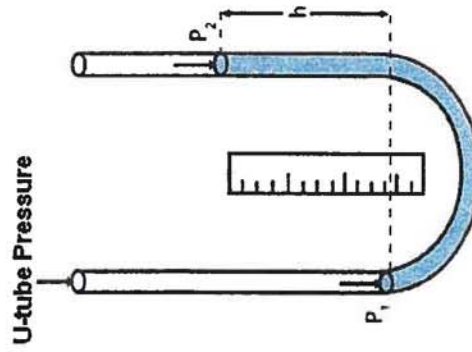

Data

- Circulate 342 bbl before cement job
- Pump nitrified foam cement
 - Pumped 60 bbl cement
- Estimated TOC at 17260'
- Bumped plug with 1150 psi
 - Cement in place at 00:35
 - Bled back 5 bbls to 0 psi
 - Minimal calculated U-tube pressure after job (nearly balanced)
- 14.0 ppg mud in rathole with 16.7 ppg cement in shoe track

Interpretation

- Job pumped per plan – no cement losses observed
- Minimal U-tube may have prevented definitive float test
- Potential for contamination of cement in shoe track due to density difference between cement and mud



Set Seal Assembly - Lay Down Landing String

Draft – Work in Progress. Subject to Revision

00:30 - 07:00

4/20/10

Close Upper VBR's to test seal assembly.
Test successful

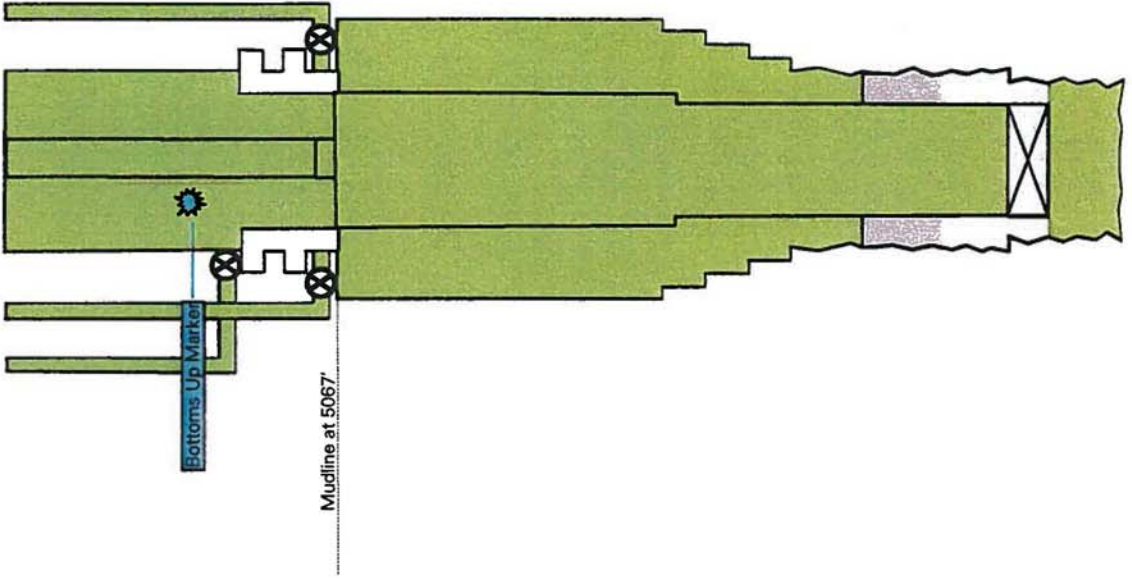

<u>Data</u>
<ul style="list-style-type: none"> • Release running tool • Set seal assembly at 5059' to seal the 9-7/8" casing annulus • Successful pressure test of seal assembly • Setting and testing procedure as per plan • Begin tripping out

<u>Interpretation</u>
<ul style="list-style-type: none"> • Set and test of seal assembly is normal



Trip in and Casing Test

Subject to Revision

Draft – Work in Progress

250/
2500
psi

Kill

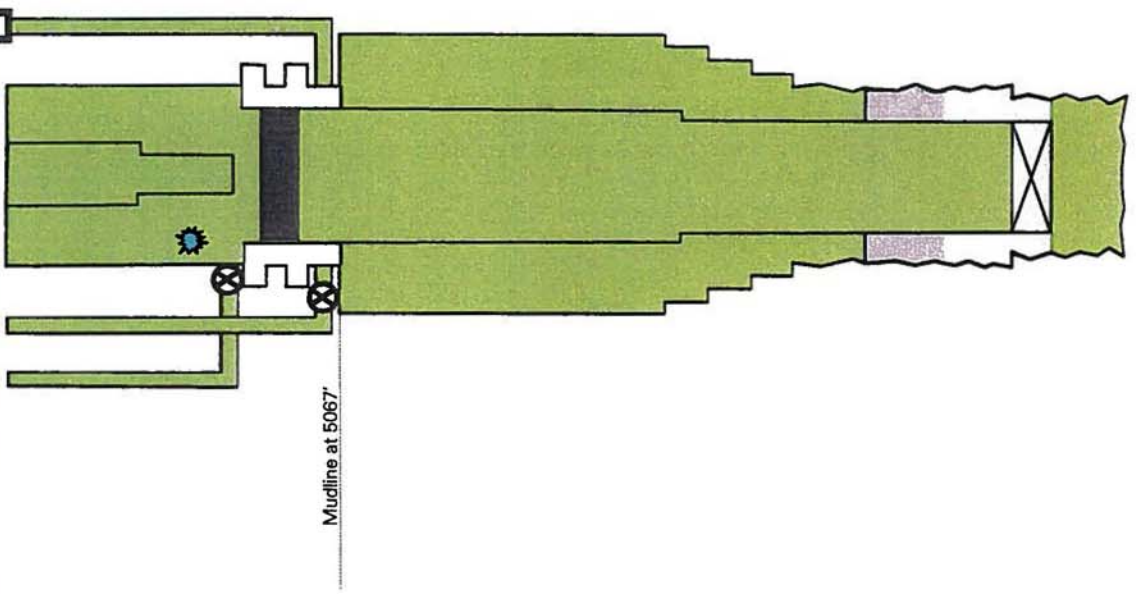

07:00 - 12:00

4/20/10

12:00 – Close BSR. Pump down kill line to test casing to 250/2500 psi for 30 min

Data

- Run in with tapered string for cement plug:
 - 6-5/8" x 5-1/2" x 3-1/2" drill pipe
- Stop at 4700' (above BOP)
- Close blind shear rams
- Positive test casing to 250 and 2500 psi

Interpretation

- Positive casing test is successful
 - Pressures and volumes are as expected



Finish Trip in Hole

Draft – Work in Progress. Subject to Revision

12:00 - 15:00
4/20/10

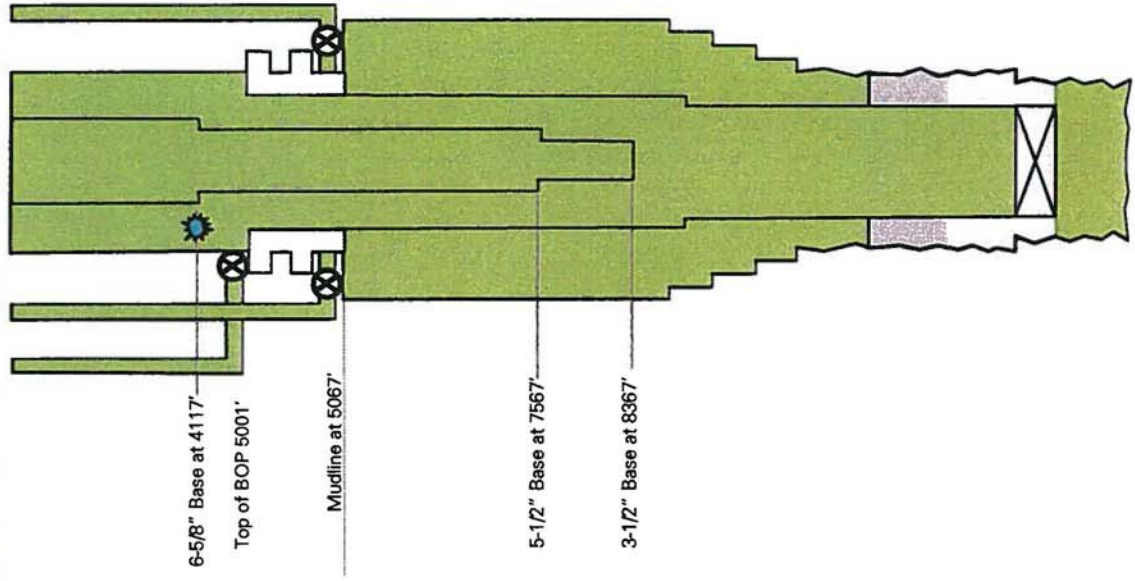

Data

- Finish RIH to 8367'
- Mud transfer to boat begins at 13:28

Interpretation

- The approach to transferring mud may have impaired pit monitoring over next 4 hours



Displace Boost, Choke, and Kill Lines

Draft – Work in Progress Subject to Revision

15:04 - 15:54

4/20/10

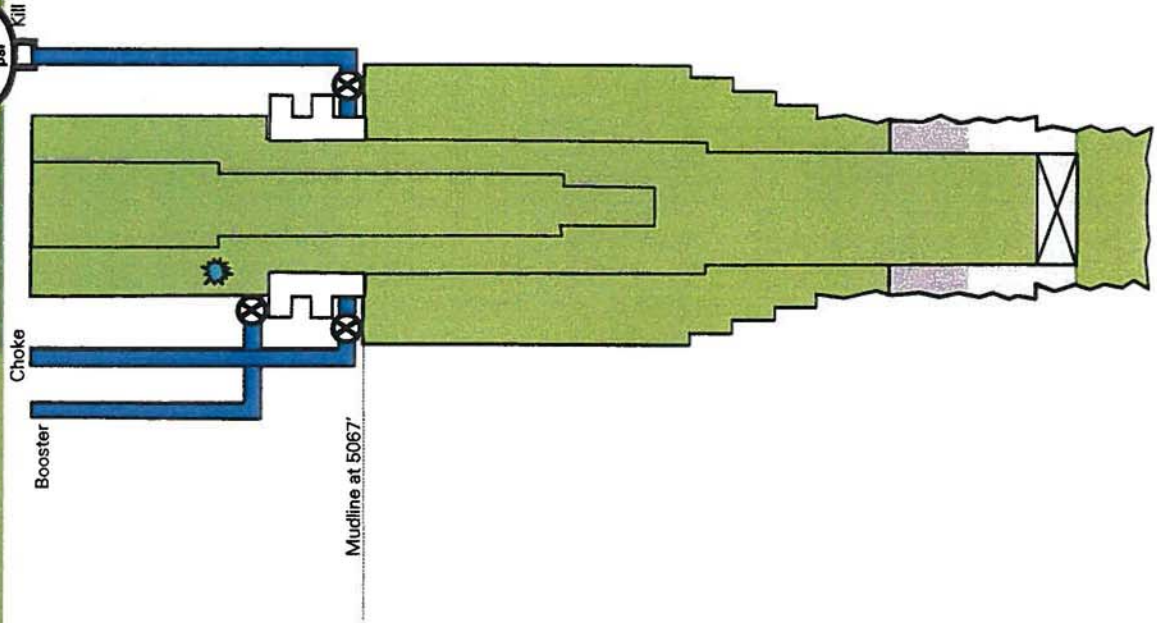

Data

- Displaced booster line w/ seawater
- Displaced choke line with seawater
- Displaced kill line with seawater
- 1200 psi trapped in kill line

Interpretation

- Close booster, choke, and kill line bottom valves after displacements



Pump Spacer

15:56 - 16:28

4/20/10

Draft – Work in Progress Subject to Revision

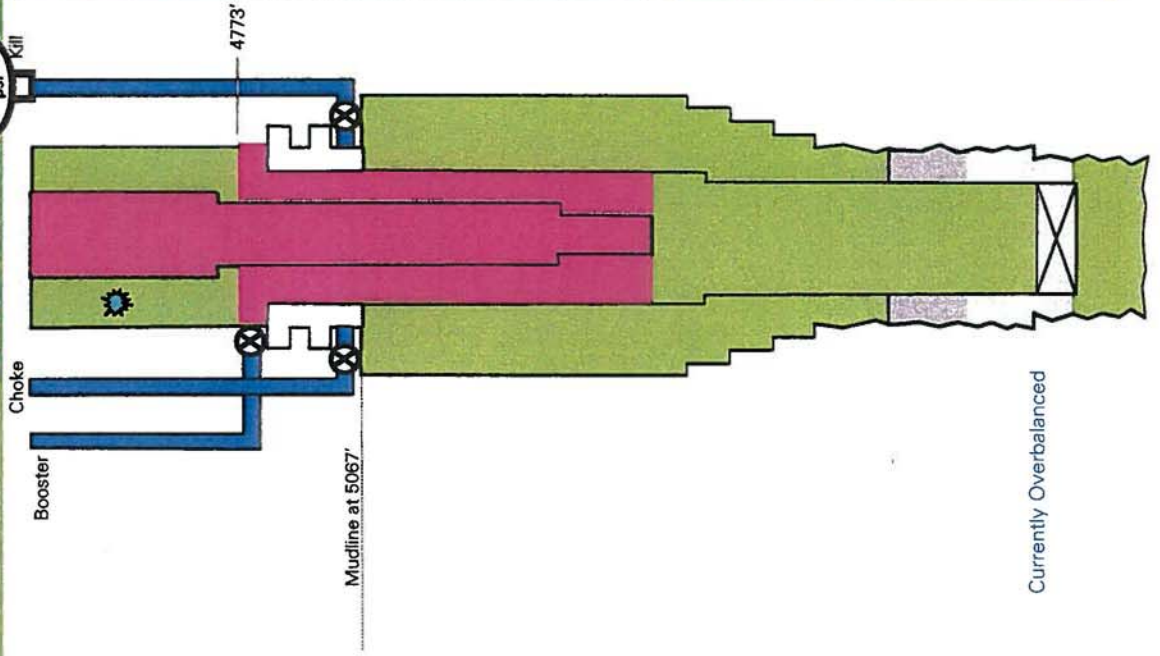

Data	
•	Pump 454 bbbls LCM spacer (16.0 ppg)
–	Form-a-Set + Form-a-Squeeze combination
–	Viscous, solids-laden fluid
•	Kill line pressure holds at 1200 psi

Interpretation	
•	Any gas from the cement job should be to surface by this point
–	No abnormal gas shows seen

Legend	
Green	= 14 ppg Mud
Pink	= 16 ppg Spacer
Blue	= 8.6 ppg Seawater



Pump Seawater

16:29 - 16:52

4/20/10

Draft 2325 psi Subject to Revision 1200 psi Kill



Data

- Pump 352bbbls seawater
 - Not enough to get spacer above BOP
- 2325 psi static pressure after pumping
 - Calculated U-tube is 1628 psi

Interpretation

- Higher than expected static pressure may indicate large spacer-to-water interface
- Significant solids settling expected once pumps stop
- High gel strength with 100% spacer

Legend
 Green = 14 ppg Mud
 Pink = 16 ppg Spacer
 Blue = 8.6 ppg Seawater

Currently Overbalanced

Draft – Work in progress. Not all information has been verified / corroborated. Subject to review in light of additional information or analysis



Shut Annular

16:53 - 16:55
4/20/10

Draft 2325 psi Subject to Revision

1200 psi Kill

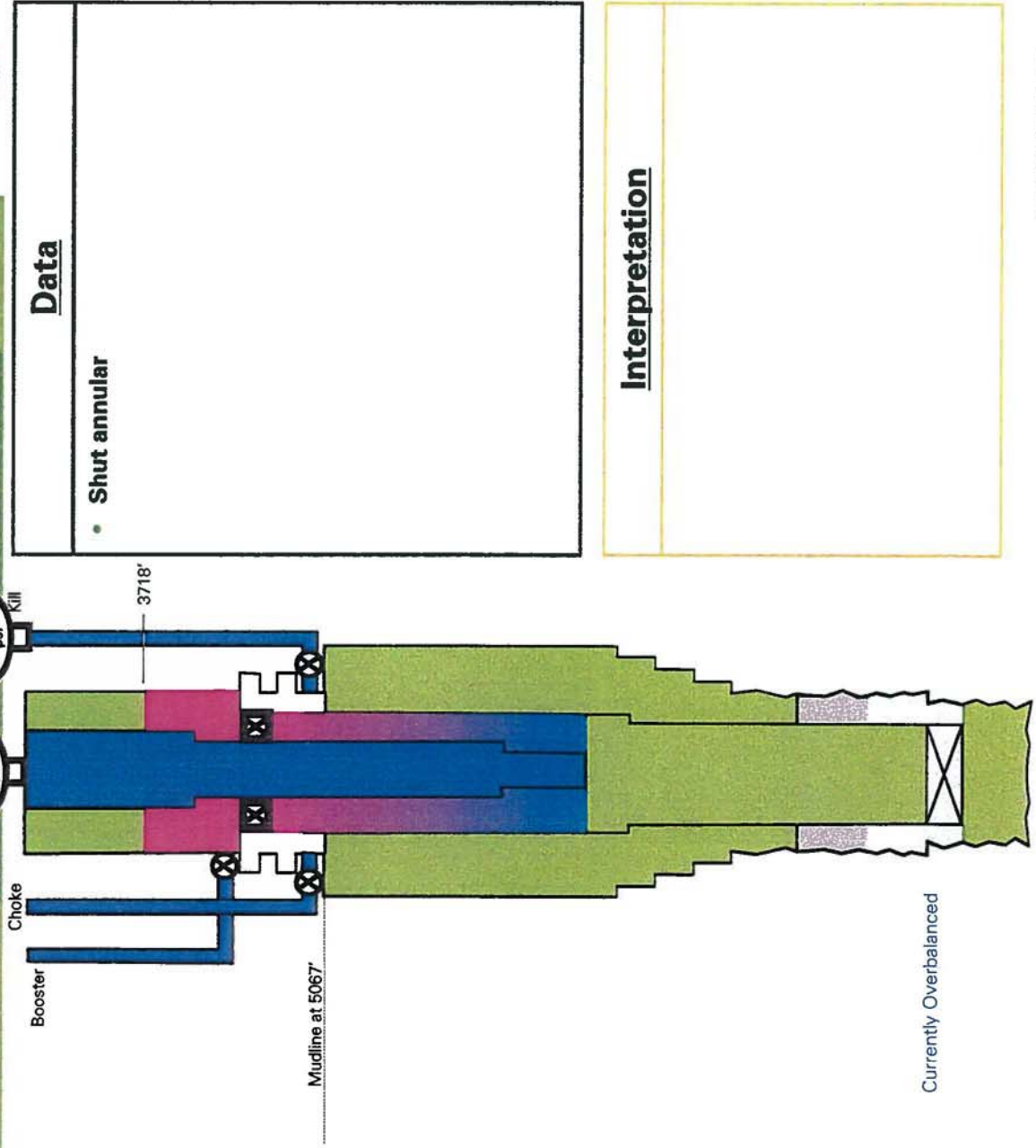

Currently Overbalanced

Data

- Shut annular

Interpretation

Legend
 Green = 14 ppg Mud
 Pink = 16 ppg Spacer
 Blue = 8.6 ppg Seawater



Bleed to 1220 psi

16:55 - 16:57

4/20/10

Draft 1220 psi Subject to Revision

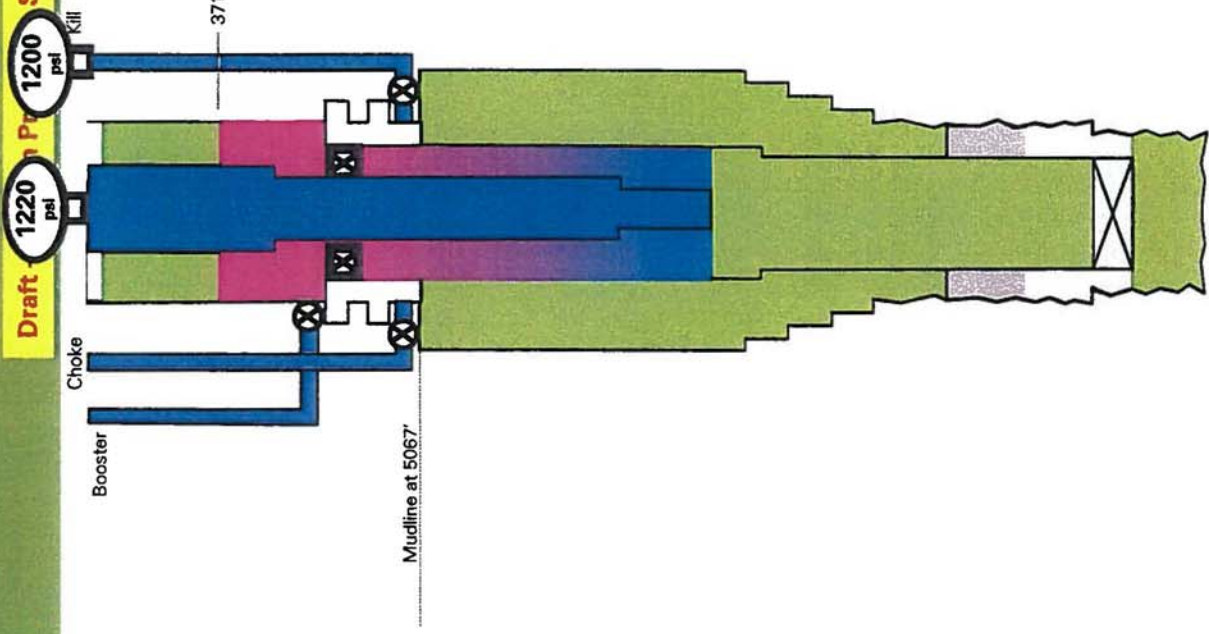

Data

- Bleed drill pipe pressure from 2325 psi to 1220 psi to equalize with kill line

Interpretation

Legend
 Green = 14 ppg Mud
 Pink = 16 ppg Spacer
 Blue = 8.6 ppg Seawater



Bleed to 273 psi

16:57 - 17:05

4/20/10

Draft 1220 psi
Kill 1200 psi
Subject to Revision

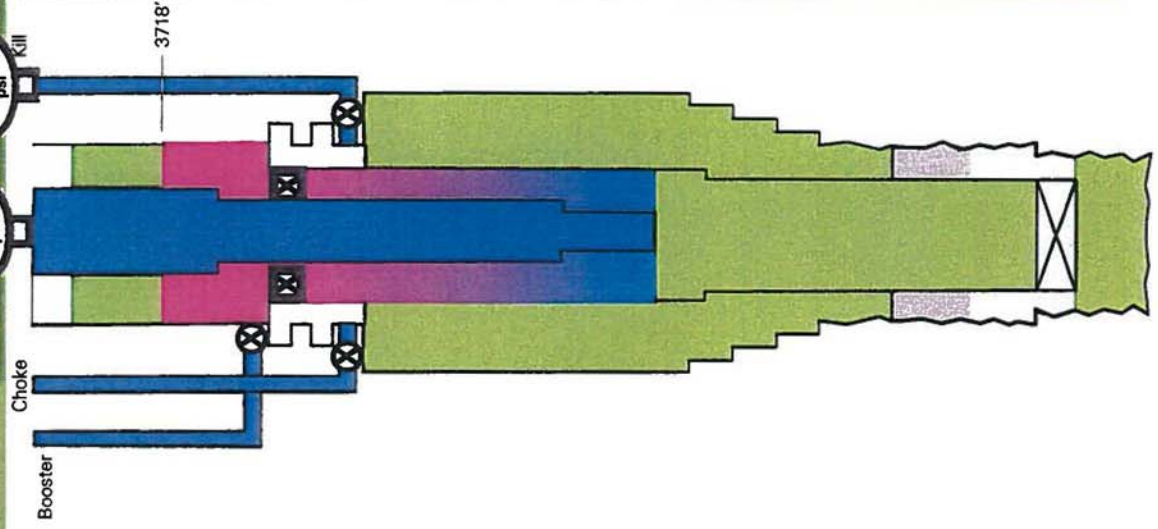

Data

- Open kill line
- Pressure equalizes
 - Drillpipe pressure goes to 1400 psi
 - Kill line pressure drops to 645 psi
- Bleed pressure to 273 psi on drillpipe as kill line pressure drops to zero
 - DP pressure never gets to zero
- First time well is under balance
- Observed that fluid level in the riser had dropped

Interpretation

- U-tube between drill pipe and kill line due to heavy fluid in the annulus
- Suspect the annular is leaking

Legend
 Green = 14 ppg Mud
 Pink = 16 ppg Spacer
 Blue = 8.6 ppg Seawater



Drillpipe Pressure Builds / Fill Riser

Draft 1250 psi Subject to Revision

17:05 - 17:25
4/20/10

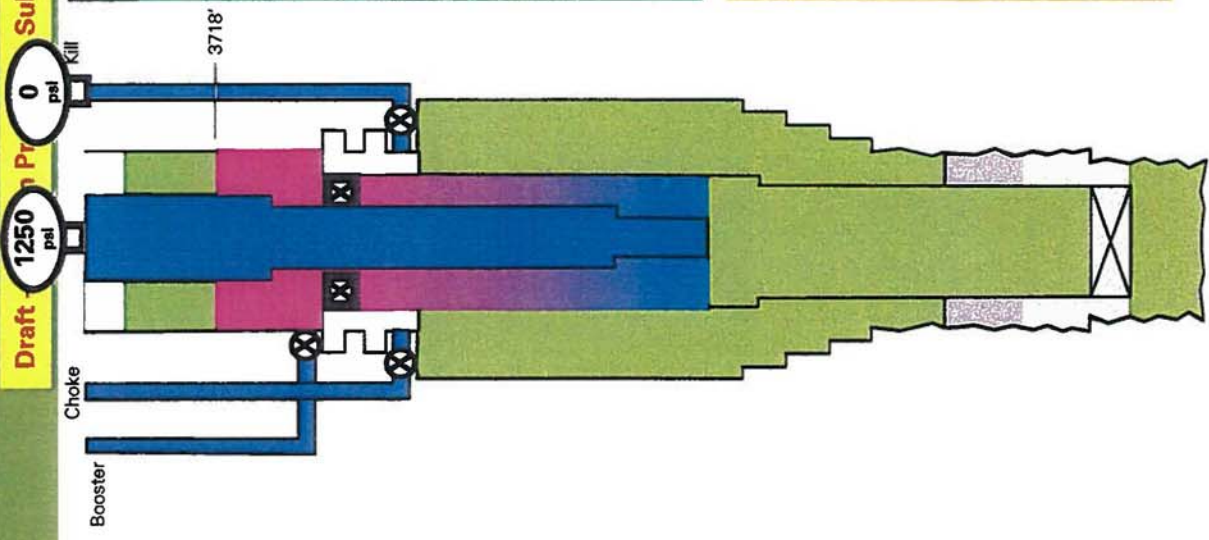

Data

- Shut in drillpipe
- Pressure builds to 1250 psi in 6 minutes
- Filled the riser with 50bbbls from trip tank
- Mud offload to Bankston ends at 17:17
 - Mudloggers not informed that offloading had ceased

Interpretation

- If the annular was leaking it is now sealed
- Discussion on rig floor about pressure on drillpipe
 - Decision made to conduct negative test on kill line

Legend
 Green = 14 ppg Mud
 Pink = 16 ppg Spacer
 Blue = 8.6 ppg Seawater



Bleed from 1202 to 0 psi

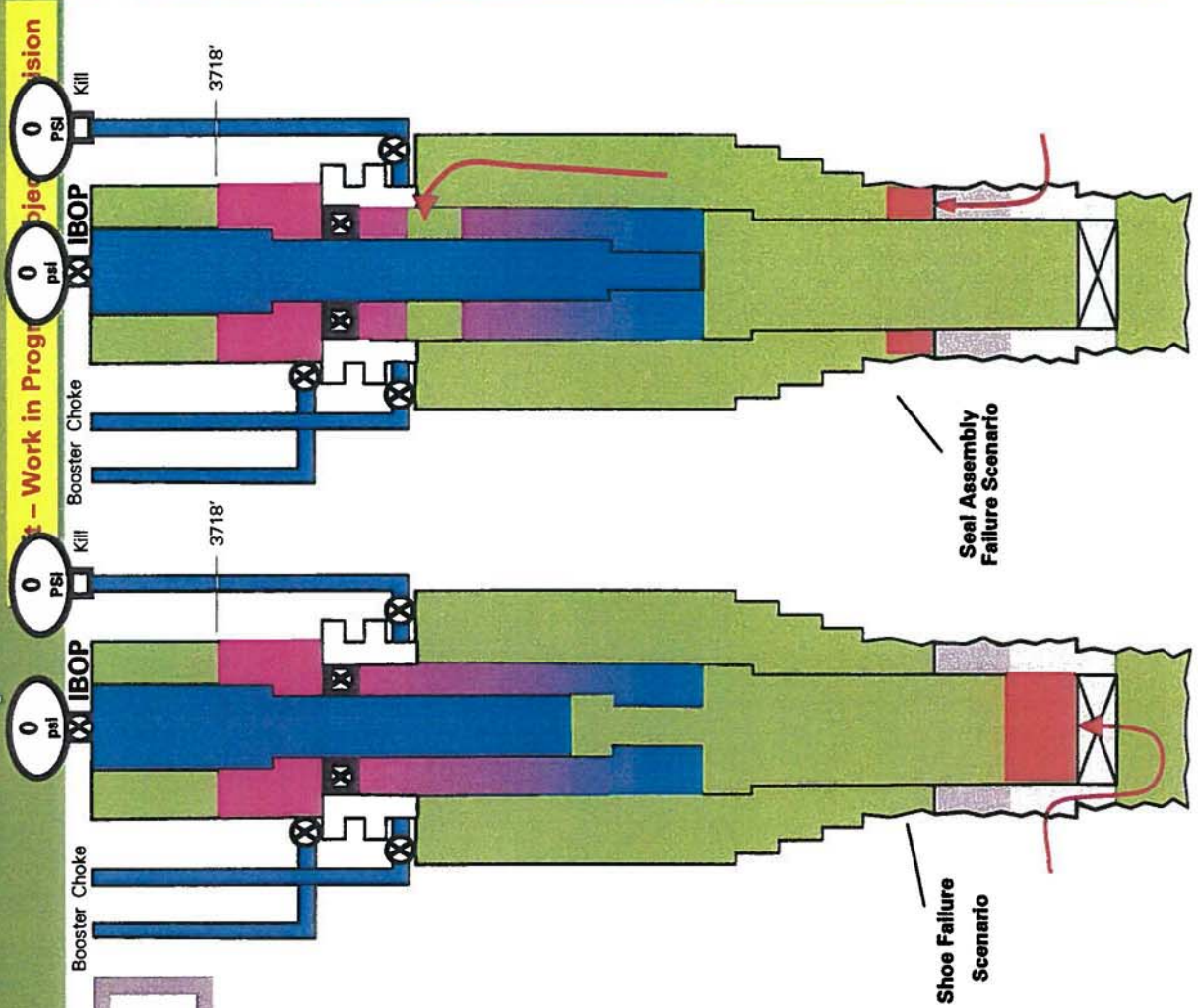

17:27 - 17:52
4/20/10



Data
<ul style="list-style-type: none"> Bleed drillpipe from 1202 to 0 psi IBOP is then closed

Interpretation
<ul style="list-style-type: none"> Witness statements indicate 15 bbls taken at this bleed <ul style="list-style-type: none"> Normal compressibility would be approximately 5 bbls Influx from the well is suspected

Legend
Green = 14 ppg Mud
Pink = 16 ppg Spacer
Blue = 8.6 ppg Seawater



Pressure Holds – Negative Test

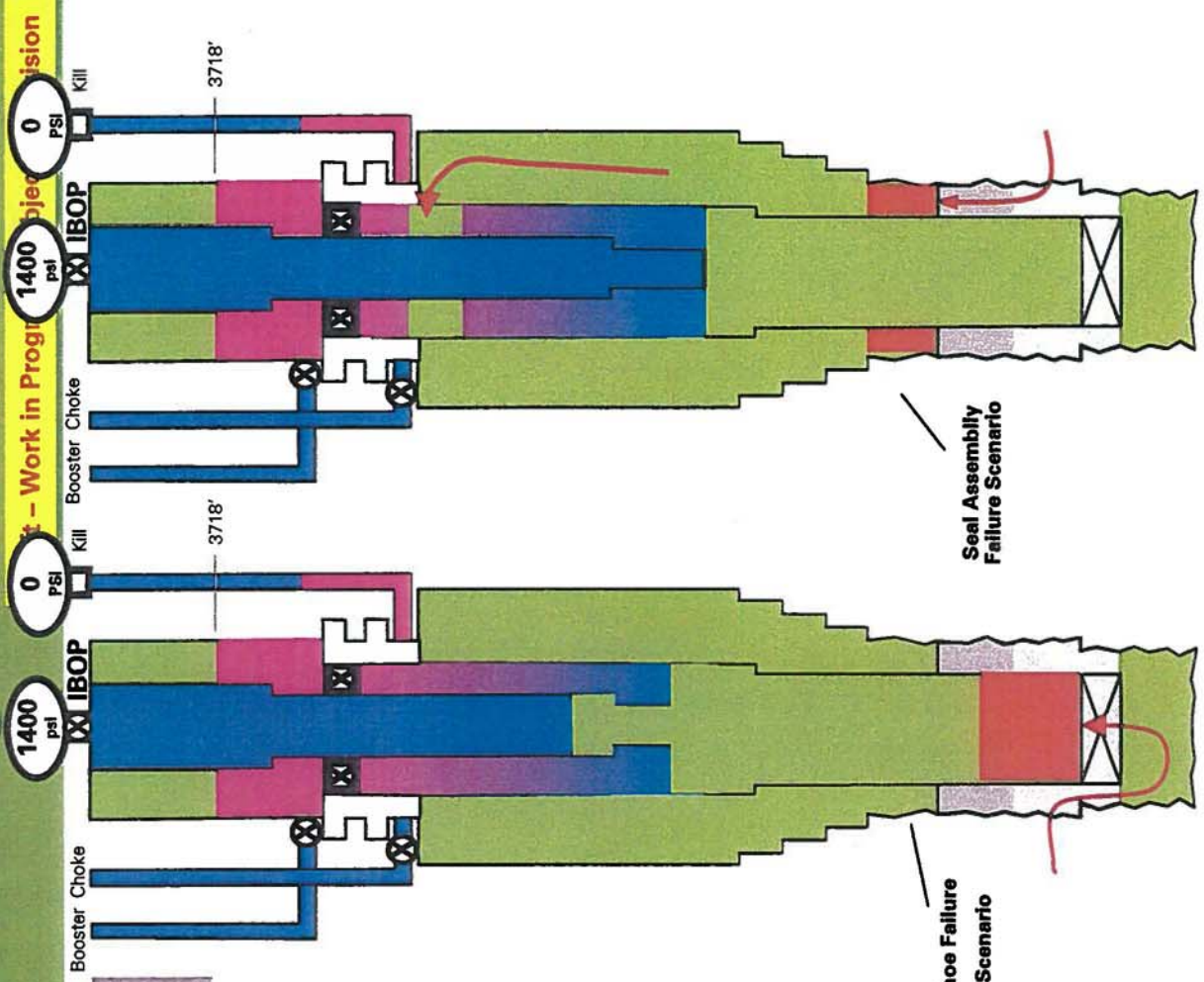

18:40 - 19:55
4/20/10



Cumulative Gain

Legend	
Green	= 14 ppg Mud
Pink	= 16 ppg Spacer
Blue	= 8.6 ppg Seawater

Data	
•	Drillpipe pressure (monitored at Halliburton) stays steady at 1400 psi
•	Pumped on kill line to ensure full
•	Bled off 0.2 bbls to trip tank
•	Monitored kill line for 30 minutes
•	Prepare to displace with seawater

Interpretation	
•	Discussion about pressure on the drillpipe
•	No flow observed on kill line
•	Rig team satisfied that test successful



Displace to Seawater

Draft – Work in Progress. Subject to Revision

19:55 - 21:14

4/20/10

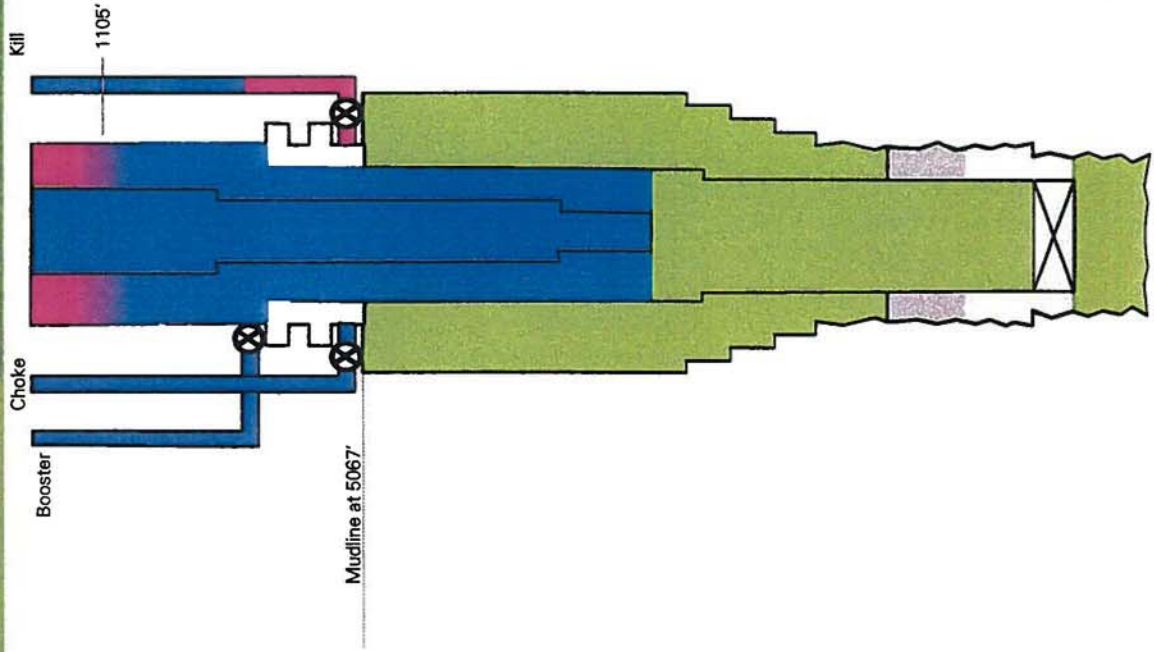

Data

- Pumped 1304 bbl seawater
 - Using rig pumps and booster
- Shut down for sheen test – spacer back
 - 1017 psi on DP when shut down
- Sheen test passes
- Crew instructed to divert returns overboard

Interpretation

- Flow out greater than flow in commencing at 20:58 while slowing pumps for spacer return
- Second indication of flow at 21:08 when pumps shutdown for sheen test
 - Pressure builds to 1263 over 5.5 minute period
 - Flow meter indicates well flowing



Three Flow Indicators

Draft – Work in Progress. Subject to Revision

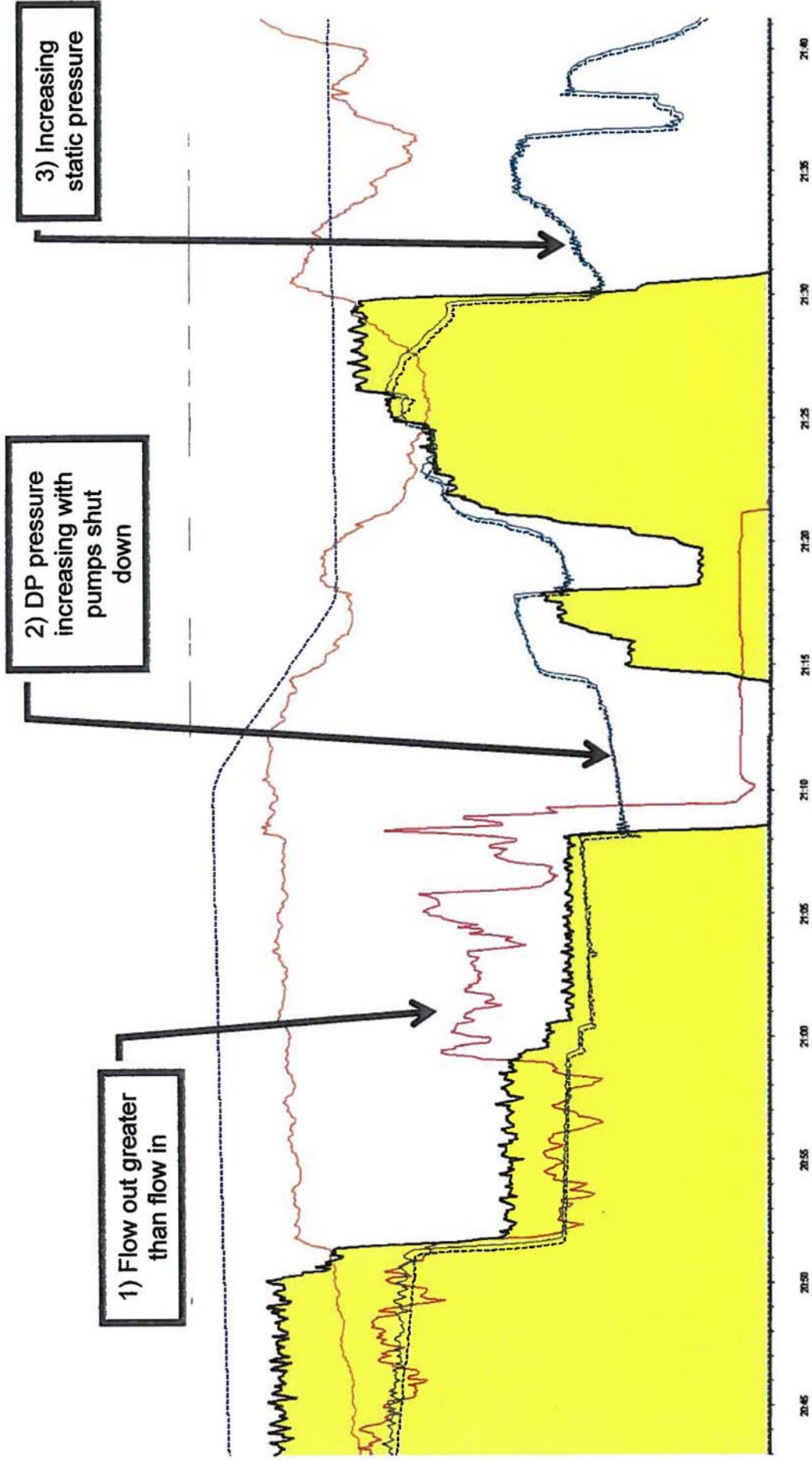



Critical Factor 2: Flow Indication #1 51 minutes before explosion

Draft – Work in Progress. Subject to Revision

- Following final integrity test of wellbore, BOP annular was opened and well displacement of mud to seawater began:
 - Flow-out volume of mud and drillpipe pressure showed expected correlation until about 20:58
 - At 20:58, pumps were slowed and the following abnormal results:
 - Drillpipe pressure increased from 1250 psi to 1350 psi
 - Flow-out volume increased instead of slowing
 - Flow-out vs flow-in shows gain of approx 57 bbls over 12 minute period
 - First indication of flow ~51 minutes before the explosion

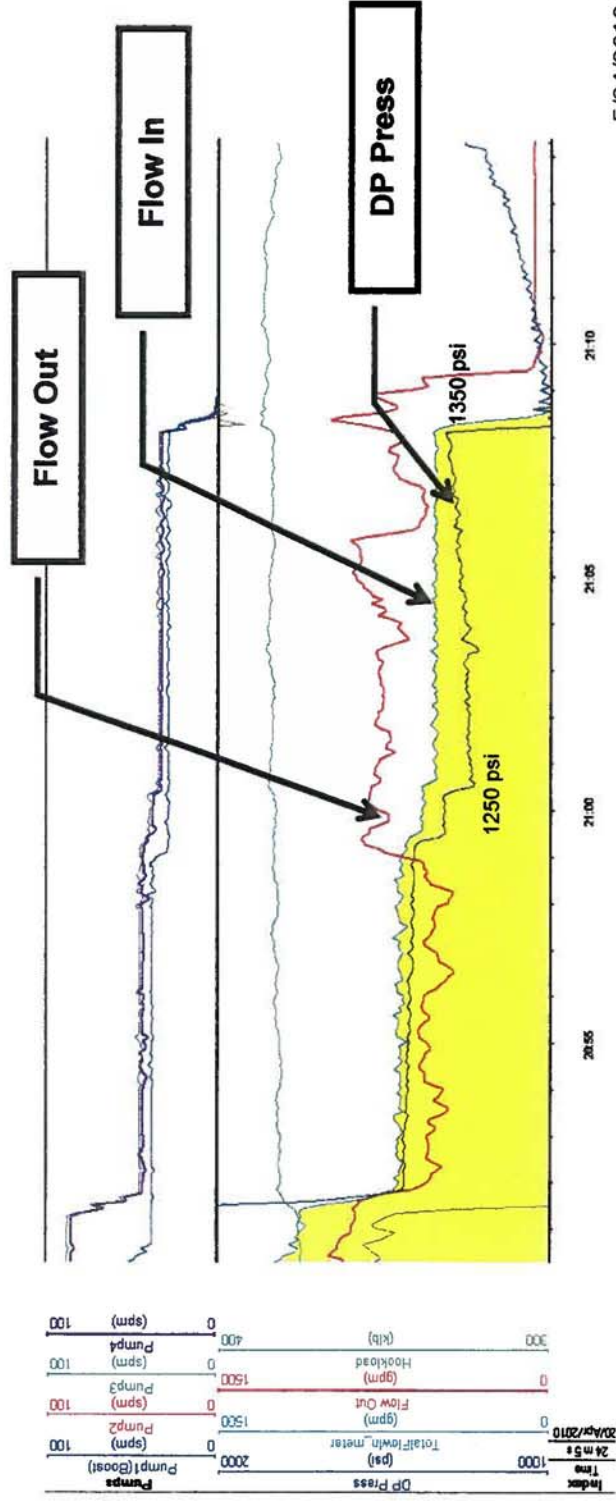



Critical Factor 2: Flow Indication #2 41 minutes before explosion

Draft – Work in Progress. Subject to Revision

- At 21:08 – pump shutdown as spacer observed at surface. Sheen test required.
 - Flow-out should be zero, but real-time data indicates well flowing after pump shut off
 - Drillpipe pressure increased from 1017 psi to 1263 psi over 5.5 minute period of sheen test

Ex) Normal Flow Back @ 16:52

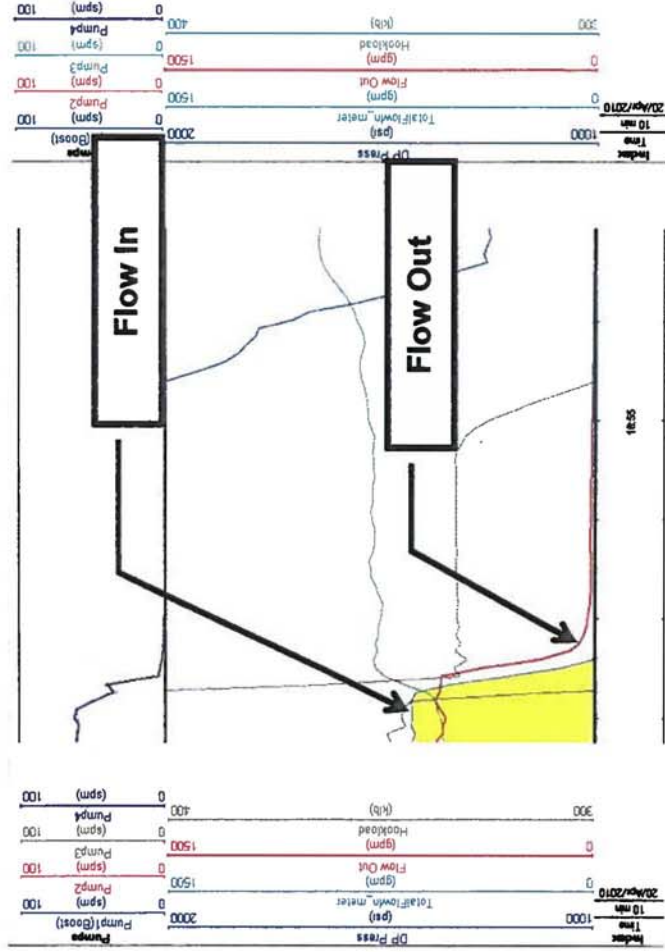

Flow Back @ 21:08

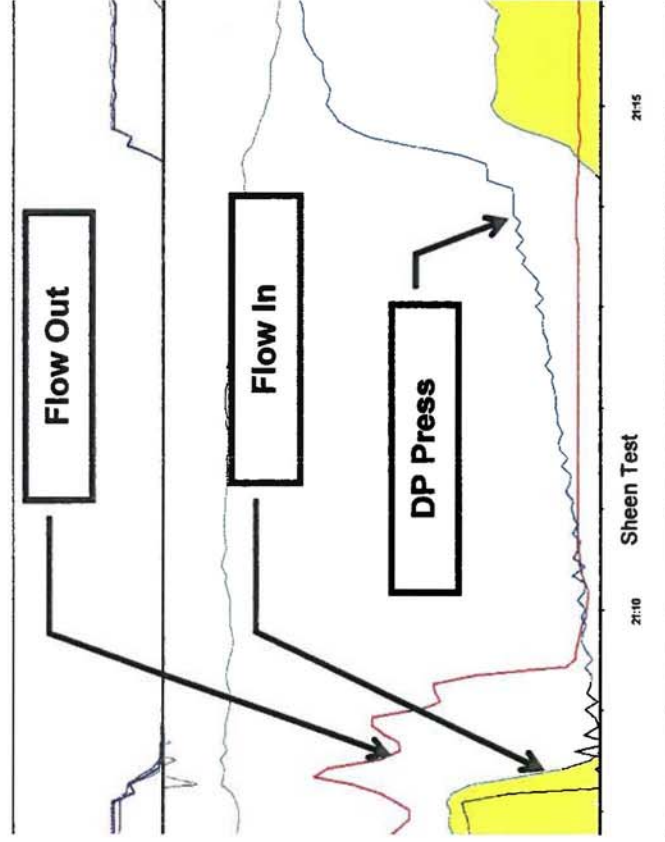



Resume Displacement

Draft – Work in Progress. Subject to Revision

21:14 - 21:49
4/20/10

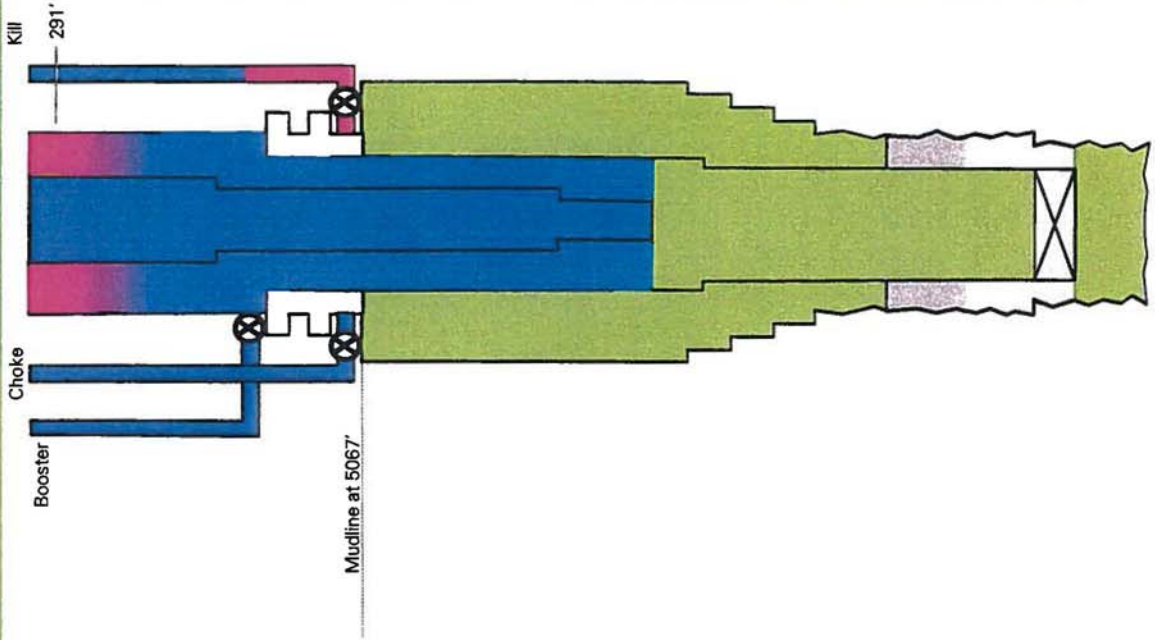

Data

- Resume displacement
 - Pump another 265 bbls
 - Returns going overboard
 - Flow meter bypassed – unable to monitor flow out
- Pumps stop at 21:31
- Significant pressure buildup starting at 21:47
- Data lost at 21:49
 - Last pressure reading 5700 psi

Interpretation

- Pumps stop at 21:31 – suspect problem identified with well
- 4 calls made from rig floor and Chief Mate discusses well with Toolpusher on rig floor
- Suspect explosion at 21:49
- EDS at 21:56 by Captain



Critical Factor 2: Flow Indication #3 18 minutes before explosion

Draft – Work in Progress. Subject to Revision

- Sheen test passed and approval granted to discharge overboard
- At 21:14, pumping resumed to continue displacement to seawater
- At 21:31, problem observed (e.g. mud returns, abnormal pressures)
 - Pump abruptly shutdown
 - Drillpipe pressure at time of shutdown was 1240 psi. Increased to 1750 psi over next 6 minutes.
 - Flow-out data not available due to fluids being discharged directly overboard (bypasses flowmeter)

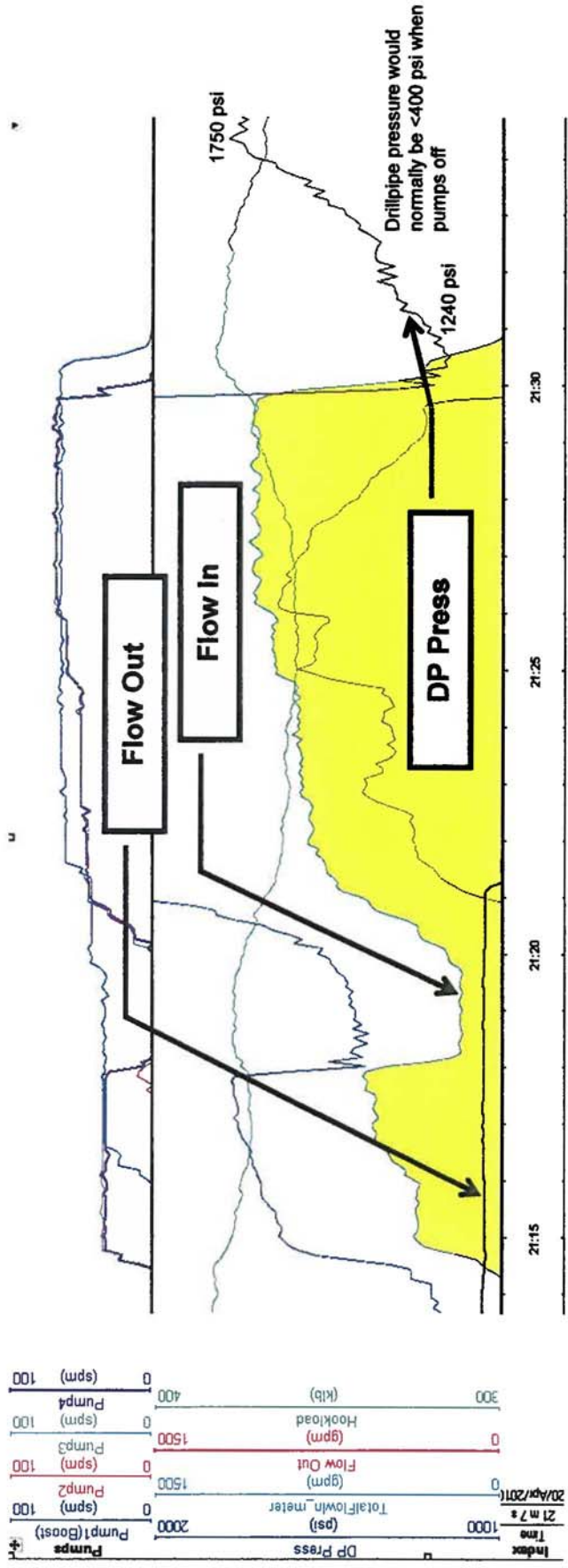



Final 18 Minutes

Draft – Work in Progress. Subject to Revision

Data lost,
suspect
explosion

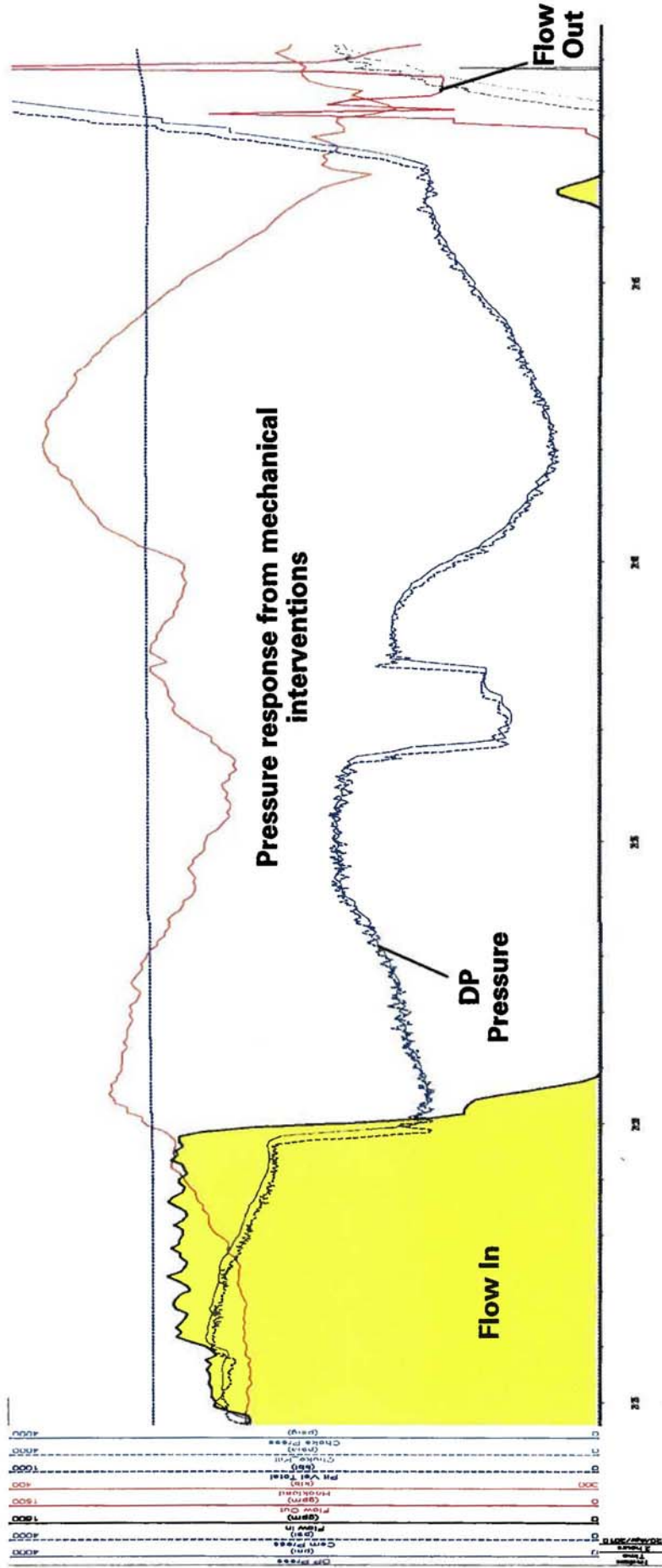



BOP - EDS (Emergency Disconnect) Function

Draft – Work in Progress. Subject to Revision

- EDS was activated from Bridge after explosion at 21:56 based on witness statements
 - Activation time for EDS is 46 seconds
- The EDS function can be activated from the surface (either the bridge or drill floor).
 - Function is to seal the well and disconnect the vessel from the well.
- The EDS sequence:
 - Operator on rig pushes the EDS button
 - Blind shear rams close cutting drill pipe and sealing the well
 - Choke and kill line valves are closed and lines unlatched
 - LMRP is unlatched and disconnects
 - The EDS sequence is now complete and rig is free to move away from well.
- In this event there is no evidence that the EDS activated, there was still significant flow from the well and the LMRP remained connected to the BOP.

BOP - AMF (Dead-man) Function

Draft – Work in Progress. Subject to Revision



- The AMF would have been expected to seal the well after loss of the three functions (hydraulics, communications and power) from the surface at some point between the explosions and the rig sinking.
- The AMF is an emergency sequence that activates the blind shear rams to seal the well.
 - Activation time for the AMF is 37 seconds
- The AMF sequence:
 - The BOP senses the loss of hydraulics, communications, power from the surface (all three need to be lost) and arms the AMF.
 - The AMF Activates the Blind shear rams cutting drill pipe and sealing the well.
 - Note that the AMF does not disconnect the LMRP.
- There is no evidence to suggest that the AMF in this case activated effectively to seal the well.

BOP - ROV Hot Stab Intervention and Surveys post incident

bp



Draft – Work in Progress. Subject to Revision

- Post the explosion, numerous ROV hot stab interventions were conducted in an attempt to activate
 - Blind Shear rams
 - Variable Pipe rams
 - LMRP Disconnect (Auto shear cut in attempt to activate blind shear rams)
- ROV survey found a number of hydraulic leaks on the system
- ROV identified hydraulic system errors such that test rams were being activated instead of lower variable rams
- ROV identified undocumented modifications to the hydraulic control system; the extent of these modifications is unknown at this time
- Non-destructive examination using ultra-sonics and gamma source were conducted to try and detect position of rams and locks
- There are indications that the BOP blind shear and variable rams have moved and may be in the locked position, final determination may be possible with the recovery of the BOP



Immediate Lines of Inquiry

Draft – Work in Progress. Subject to Revision

- **Maintenance**
 - Were the BOP and control system properly maintained?
- **Testing**
 - Was the BOP properly tested within regulation; were the primary emergency systems EDS, AMF, Autoshear and ROV Hot Stabs tested regularly?
- **Modifications**
 - Are there as built diagrams of all modifications; is there a record of acceptance testing prior to running the BOP?
 - Did modifications conducted over life of BOP impact functionality?
- **Leaks**
 - Did hydraulic leaks found during ROV interventions and previously noted in Rig log impact functionality?

Draft – Work in progress. Not all information has been verified / corroborated. Subject to review in light of additional information or analysis



Backup material

BOP Function Description



Draft – Work in Progress. Subject to Revision

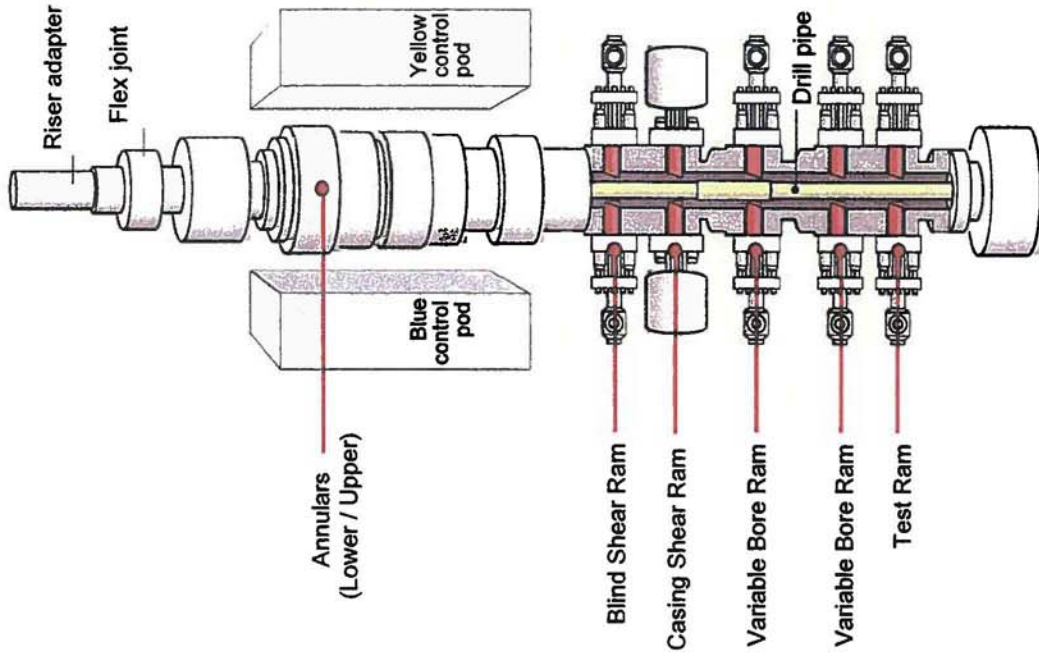

- **UAP Upper Annular Preventer** used in normal drilling operations for well shut-in rated 10K.
- **LAP Lower Annular Preventer with Casing Stripping Element..** Used for casing stripping purposes, down rated to lower wellbore retaining pressure 5K.
- **BSR Blind Shear Rams** Cuts drill pipe and seals the well.
- **CSR Casing Shear Rams Non-Sealing,** cuts drill pipe and casing; is not designed to seal the wellbore.
- **UPR Upper Pipe Rams** Ram packers can close on a range of drill pipe from 3 1/2" OD to 6 5/8" OD and seal up to 15K wellbore pressure.
- **MPR Middle Pipe Rams** Ram packers can close on a range of drill pipe from 3 1/2" OD to 6 5/8" OD and seals up to 15K wellbore pressure, can also be stripped through to hang-off drill pipe up 600K
- **LPR Lower Pipe Rams .** Test Ram seals up to 15K pressure from above.

bp

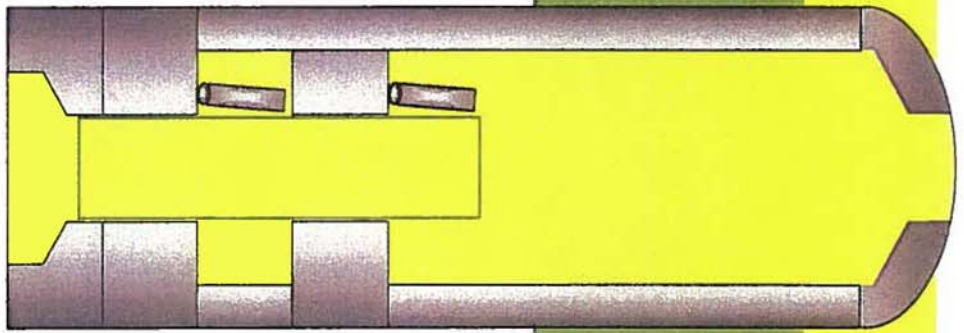
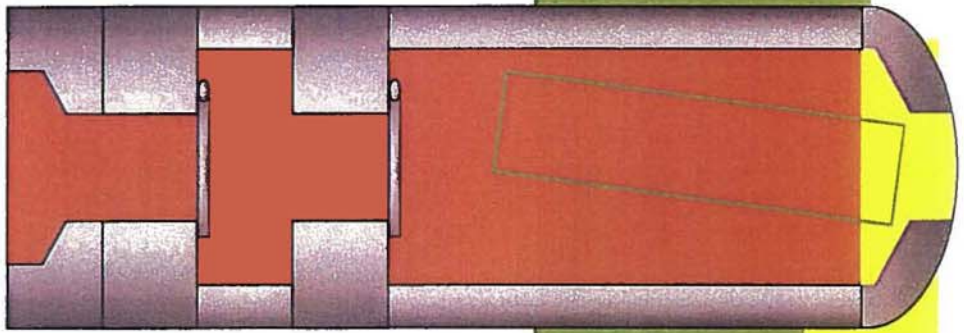
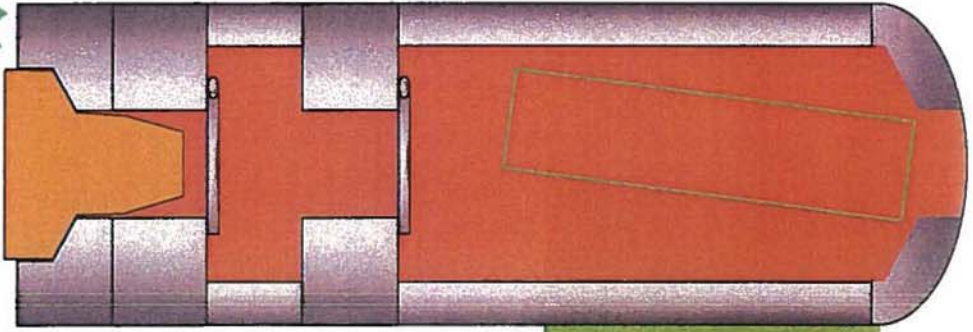

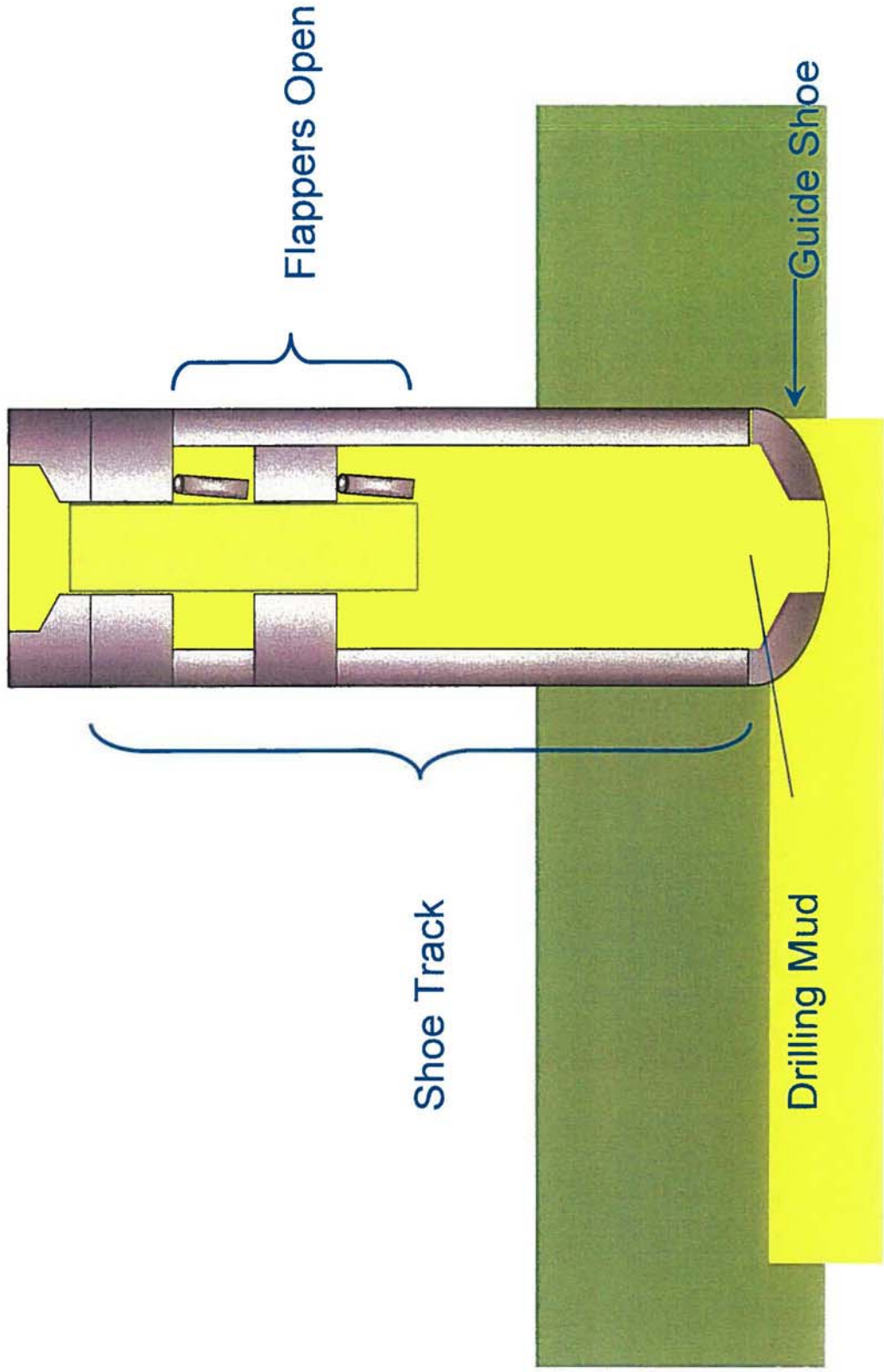

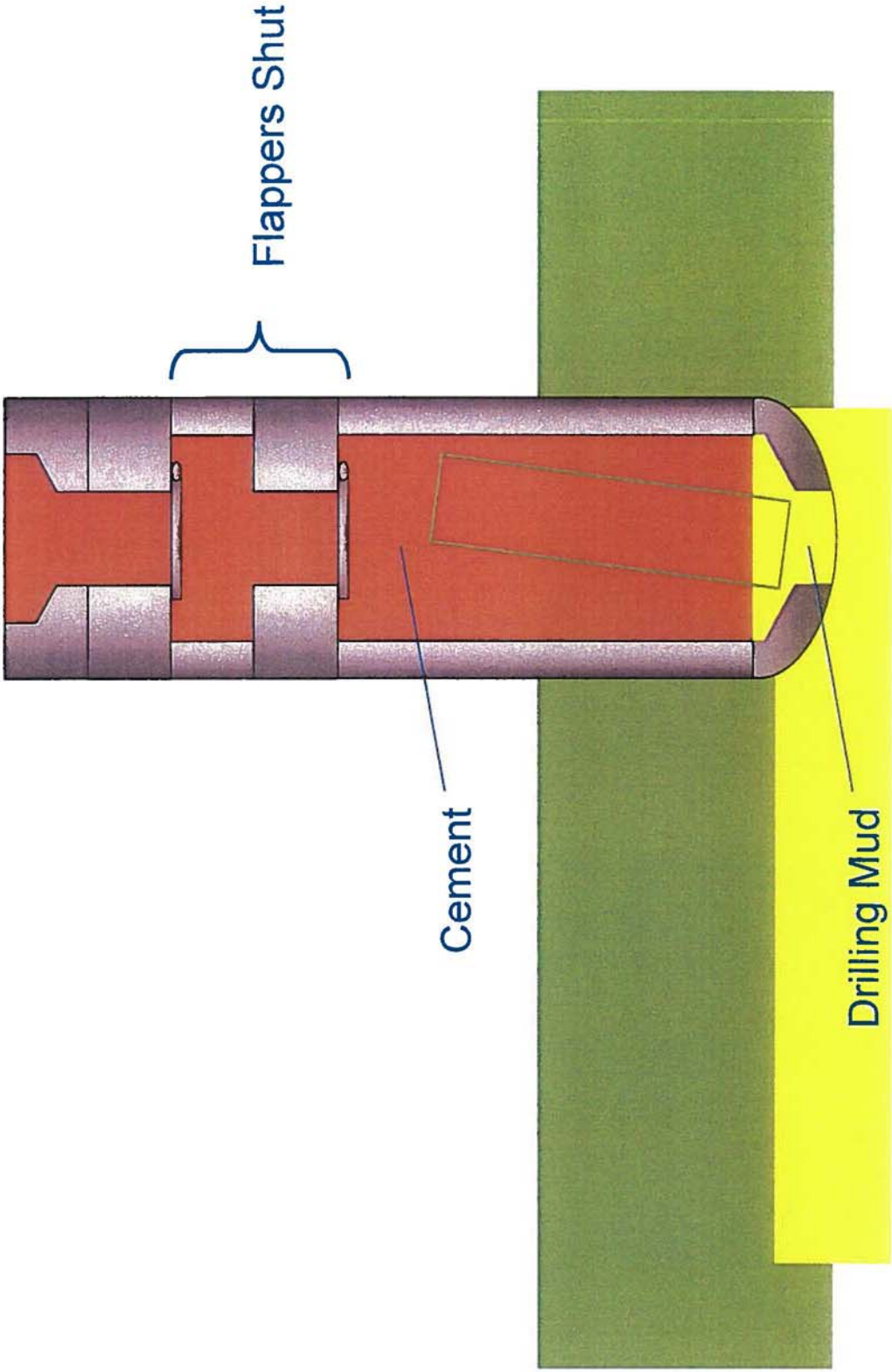

bp

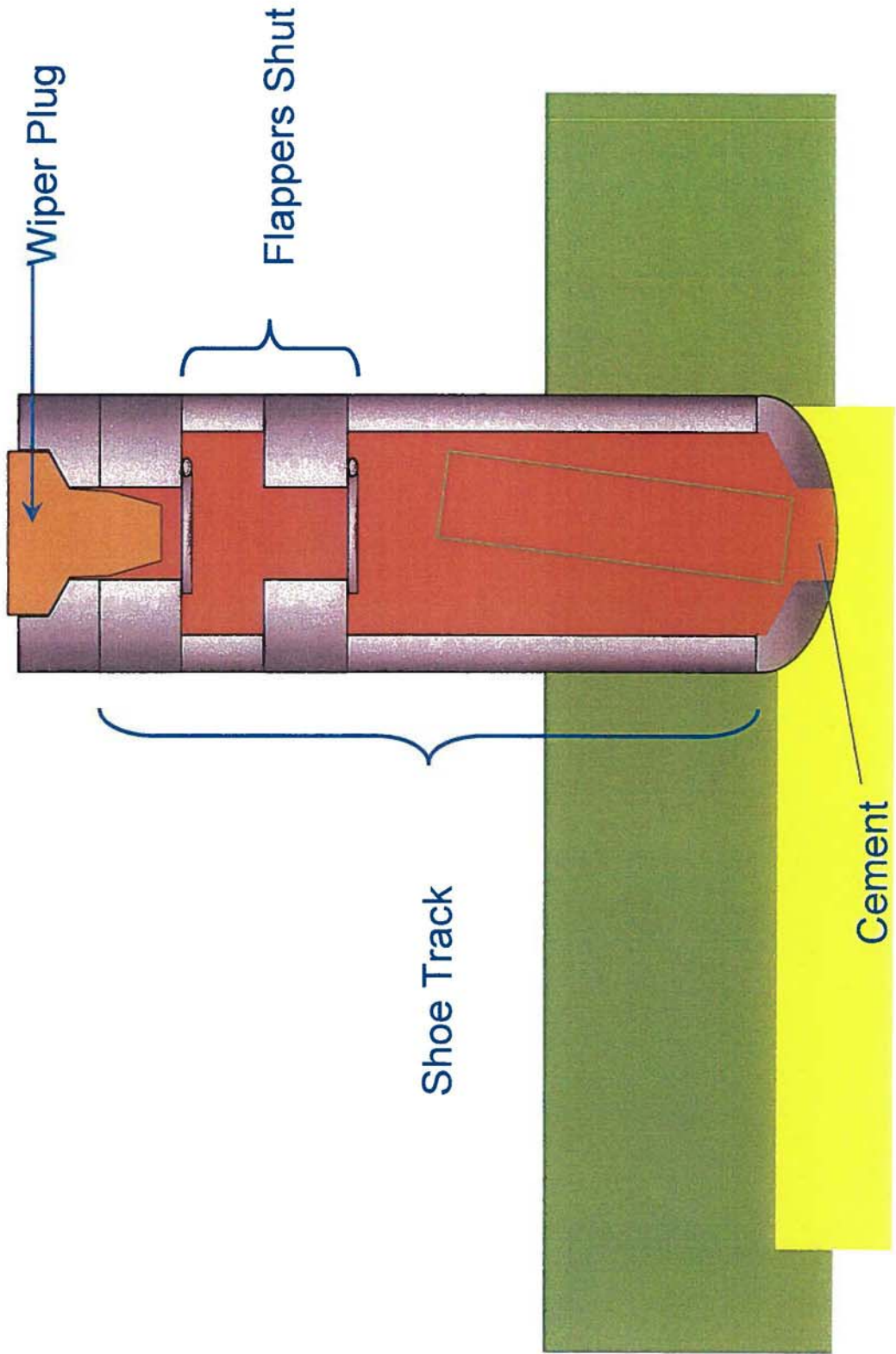



Seal Assembly With Casing Hanger Lock Down Sleeve

Draft – Work in Progress. Subject to Revision

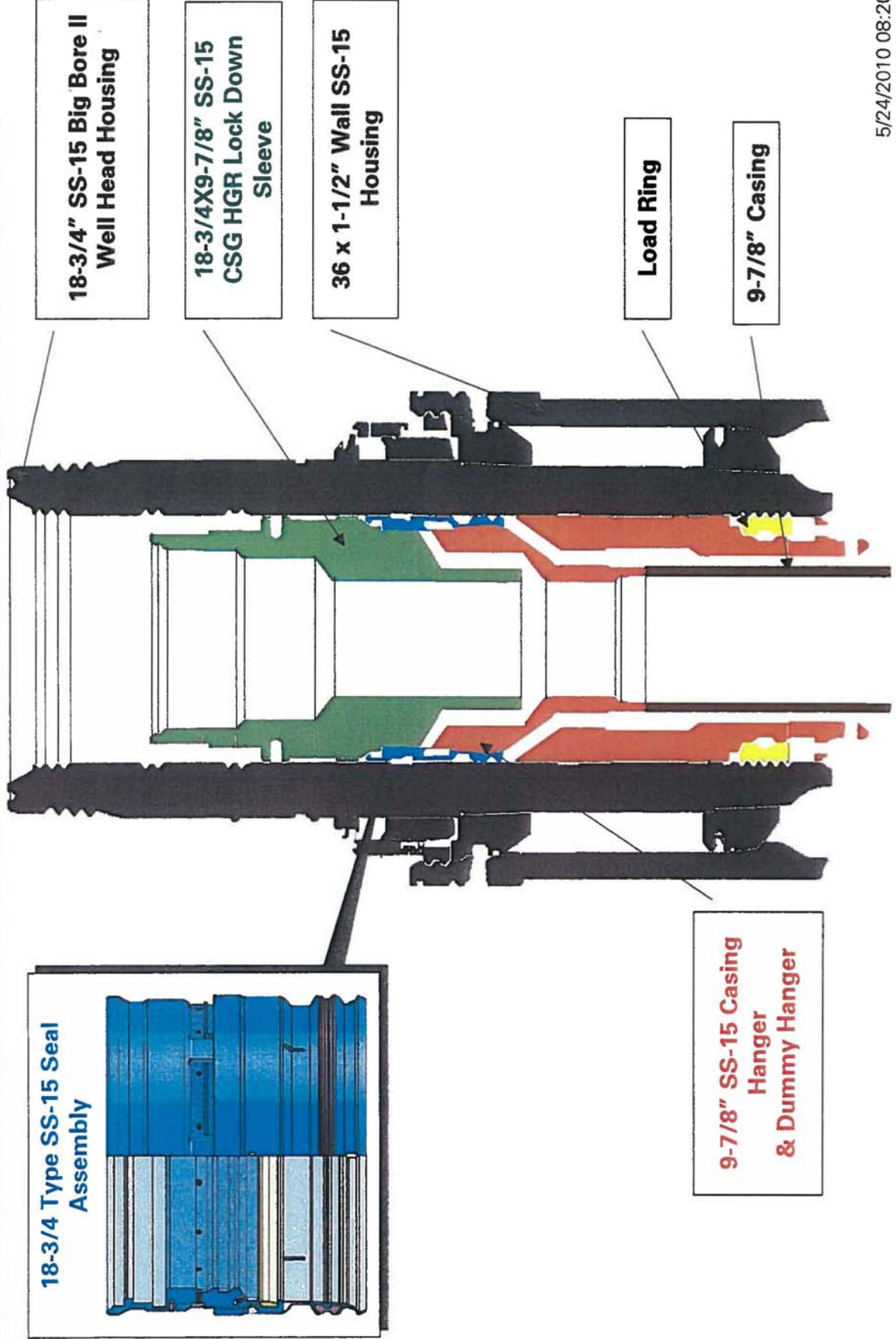

Draft – Work in progress. Not all information has been verified / corroborated. Subject to review in light of additional information or analysis



Seal Assembly Without Casing Hanger Lock Down Sleeve

Draft – Work in Progress. Subject to Revision

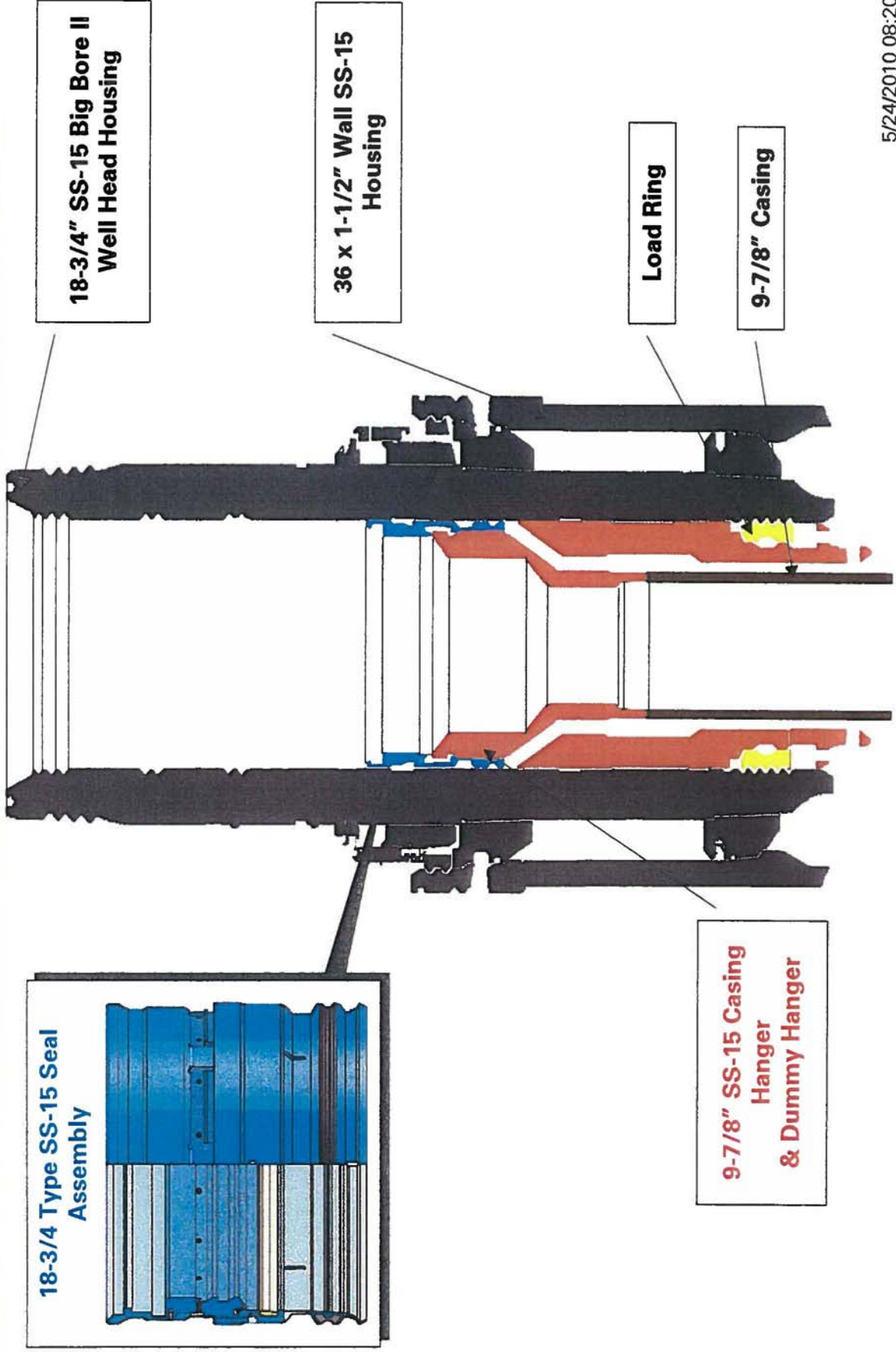

Draft – Work in progress. Not all information has been verified / corroborated. Subject to review in light of additional information or analysis



Seal Assembly Cross Sectional View

Draft – Work in Progress. Subject to Revision

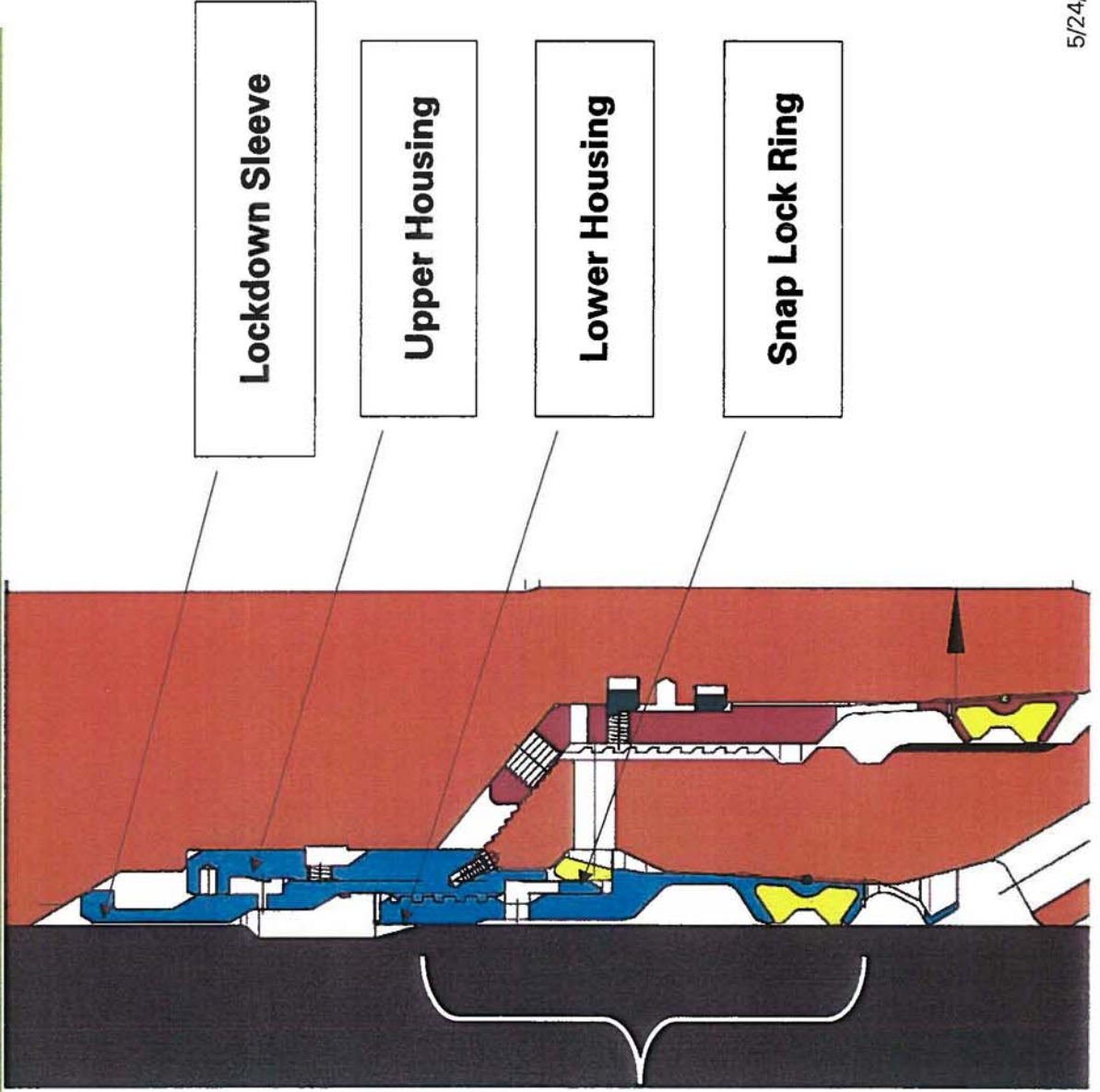

6" Seal Area



Background to Incident

Draft – Work in Progress. Subject to Revision

24 May, 2010

- **Macondo Prospect MC 252 ILX well - total depth 18,360'**
 - Challenging well to drill but comfortably within experience range
 - The well was originally spud with the Marianas Rig on Oct 6th 2009 - The Marianas sustained damages during Hurricane /da on Nov 8th and commenced tow to shipyard for repairs on Nov 26th
 - The Deep Water Horizon re-entered the well on Feb 9th 2010 at the 18" casing point
 - Both rigs are Transocean owned
 - The well encountered commercial hydrocarbons - plan was to temporarily suspend the well for future completion as a production well
- **Deepwater Horizon**
 - On contract to BP since 2001
 - Proven track record in deepwater exploration drilling (just came off record Tiber exploration well)
- **Event**
 - Incident occurred during the suspension phase of the well - 2 hrs after completing an integrity test on the well
 - At the time of the incident drilling fluid was being displaced from the well with seawater in preparation for setting the final cement plug